



T-STYLE CARTRIDGE FILTERS



Sample Engineering Specification

All sediment filters shall be T-Style cartridge type constructed from PVC Type I, ASTM D 1784 Cell Classification 12454 or CPVC Type IV, or ASTM D 1784 Cell Classification 23447. All O-rings shall be EPDM or FKM. All filters shall have removable Type 304 stainless steel cartridge with [specify from chart] mesh perforation or reinforced screen. All filters shall be pressure rated to 200 psi for water at 73°F, as manufactured by Spears® Manufacturing Company.

Quick View T-Style Cartridge Filters Selection Chart

| PVC Part Numbers ¹ | | | | |
|------------------------------------|-----------------------|----------|---------------------------|-----------|
| Cartridge Filter Mesh ² | TF Series (Full Size) | | | |
| | Standard | | Reverse Flow ² | |
| | EPDM | FKM | EPDM | FKM |
| 16 | TF2-16 | TF3-16 | TF2-16 | TF3-16 |
| 32 | TF2-32 | TF3-32 | TF2-32 | TF3-32 |
| 50 | TF2-50 | TF3-50 | TFR2-50 | TFR3-50 |
| 76 | TF2-76 | TF3-76 | TFR2-76 | TFR3-76 |
| 100 | TF2-100 | TF3-100 | TFR2-100 | TFR3-100 |
| 150 | TF2-150 | TF3-150 | TFR2-150 | TFR3-150 |
| 200 | TF2-200 | TF3-200 | TFR2-200 | TFR3-200 |
| MTF Series (Half-Size) | | | | |
| 16 | MTF2-16 | MTF3-16 | MTF2-16 | MTF3-16 |
| 32 | MTF2-32 | MTF3-32 | MTF2-32 | MTF3-32 |
| 50 | MTF2-50 | MTF3-50 | MTFR2-50 | MTFR3-50 |
| 76 | MTF2-76 | MTF3-76 | MTFR2-76 | MTFR3-76 |
| 100 | MTF2-100 | MTF3-100 | MTFR2-100 | MTFR3-100 |
| 150 | MTF2-150 | MTF3-150 | MTFR2-150 | MTFR3-150 |
| 200 | MTF2-200 | MTF3-200 | MTFR2-200 | MTFR3-200 |

1: For CPVC, Add the letter "C" to the part number (e.g., TF2-16C)

2: Mesh sizes 16 and 32 are perforation cartridges. Same cartridge is used for Standard or Reverse Flow filtration. Mesh sizes 50 - 200 are wire cloth screen with perforated stainless steel reinforcement.

Features – PVC, CPVC

In-line T-Style Cartridge Filters provide high capacity filtration of suspended solids, dirt and debris with reusable Type 304 stainless steel filter cartridges in a variety of mesh sizes. Constructed from PVC or CPVC, this special T-style configuration may be easily ganged in parallel for increased flow and filtration capacity. Standard flow (internal-to-external) filter traps sediment inside cartridge while optional reverse flow (external-to-internal) filter traps sediment on outside of cartridge, according to user preference. Available in full-size TF Series or half-size MTF Series units with IPS size 2-1/2" socket - 3" spigot combination inlet/outlet connection that can be easily adapted to other sizes with use of reducer bushings or couplings.

- Provides In-line Protection of Process Equipment
- PVC or CPVC Construction
- EPDM or FKM O-ring Seals
- Heavy, Reinforced Type 304 Stainless Steel Filter Cartridges in Mesh Sizes 16, 32, 50, 76, 100, 150, or 200
- Standard (Internal-to-External) or Reverse Flow (External-to-Internal) Cartridge Design Option
- Bottom Cartridge Removal with Drain Plug for Cleaning, or Bleed-Off Valve Connection
- Installed Units in Parallel for Increased Filtration Capacity
- Pressure Rated to 200 psi @ 73°F
- Assemble with Silicone-Free, Water Soluble Lubricants

Cartridge Filtration Area

TF Series filter surface area = 214.9 in.² and MTF Series filter surface area = 107.5 in.². Mesh sizes 16 and 32 are perforated stainless steel, 50 to 200 mesh filters are stainless steel wire cloth with perforated stainless backing and internal wire coil to prevent filter collapse or screen blow-out.

Replacement Filter Cartridges

| Mesh Size | Full Size TF Filter Part No. | | Half Size MTF Filter Part No. | |
|-----------|------------------------------|--------------|-------------------------------|--------------|
| | Standard Flow | Reverse Flow | Standard Flow | Reverse Flow |
| 16 | FL-16-1 | same as Std. | MFL-16-1 | same as Std. |
| 32 | FL-32-1 | same as Std. | MFL-32-1 | same as Std. |
| 50 | FL-50-1 | FLR-50-1 | MFL-50-1 | MFLR-50-1 |
| 76 | FL-76-1 | FLR-76-1 | MFL-76-1 | MFLR-76-1 |
| 100 | FL-100-1 | FLR-100-1 | MFL-100-1 | MFLR-100-1 |
| 150 | FL-150-1 | FLR-150-1 | MFL-150-1 | MFLR-150-1 |
| 200 | FL-200-1 | FLR-200-1 | MFL-200-1 | MFLR-200-1 |

T-STYLE CARTRIDGE FILTERS



Dimensions

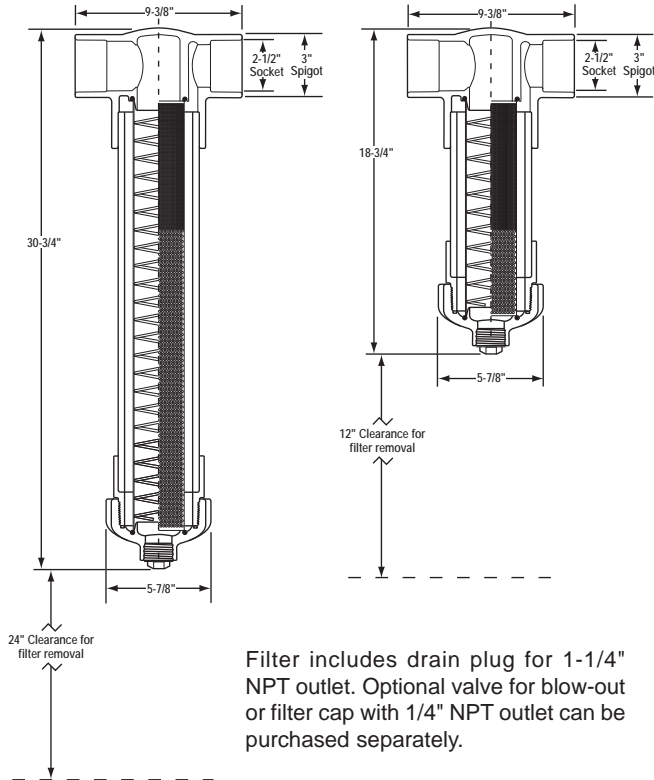

Filter includes drain plug for 1-1/4" NPT outlet. Optional valve for blow-out or filter cap with 1/4" NPT outlet can be purchased separately.

Parallel Filter Installation

For increased flow or filtration capacity, multiple filters may be installed in parallel as illustrated.

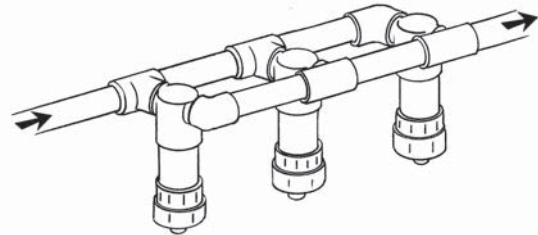

General Installation Information

Avoid installation in direct sun exposure. If required, a white, reflective latex paint coating may be applied to reduce heat absorption. Remove cartridge before solvent cement assembly into system to avoid possible cement contact with screen. Install with proper flow direction as indicated on top of the filter. Be sure to allow clearance in excess of specified space required for removal of cartridge (see drawing notes). Filter drainage or blow-down should be made in normal system flow direction to prevent screen damage. Do not "back flush" unit. Care should be taken in cleaning cartridges to avoid damaging filter screen.

T-Style Cartridge Filter Pressure Loss (Clean Filter)

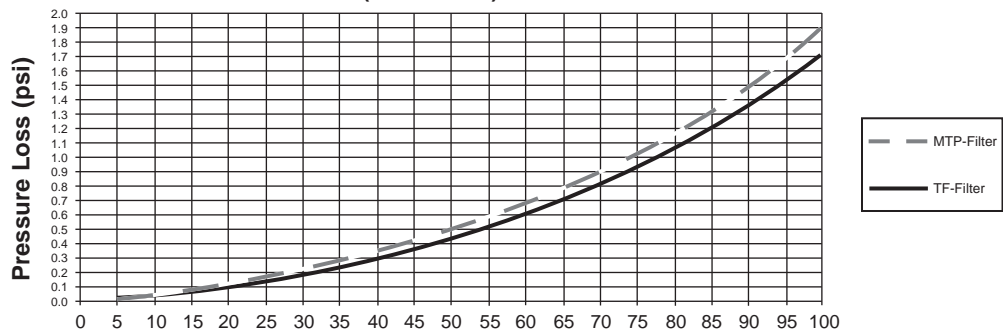

Pressure Loss

Temperature Pressure Rating

| System Operating Temperature °F (°C) | | 100 (38) | 110 (43) | 120 (49) | 130 (54) | 140 (60) | 150 (66) | 160 (71) | 170 (77) | 180 (82) | 190 (88) | 200 (93) | 210 (99) |
|--------------------------------------|------|------------|------------|-----------|-----------|-----------|-----------|-----------|-----------|-----------|-----------|-----------|-----------|
| Filter Pressure Rating psi (MPa) | PVC | 200 (1.38) | 135 (.93) | 120 (.83) | 75 (.52) | 50 (.34) | -0- (-0-) | -0- (-0-) | -0- (-0-) | -0- (-0-) | -0- (-0-) | -0- (-0-) | -0- (-0-) |
| | CPVC | 200 (1.38) | 155 (1.07) | 140 (.97) | 125 (.86) | 110 (.76) | 100 (.69) | 90 (.62) | 80 (.55) | 70 (.48) | 60 (.41) | 50 (.34) | -0- (-0-) |