



CPVC CTS FITTINGS & VALVES COPPER-TUBE SIZE



DESIGN & INSTALLATION GUIDE TECHNICAL INFORMATION



Visit our web site
www.spearsmfg.com



CPVC CTS FITTINGS & VALVES

Certified Safe Alternative to Metal Plumbing Systems



All conventional metal plumbing systems corrode leaving their corrosive wastes for deposit into the water system. CPVC thermoplastic system components never corrode. Spears® EverTUFF® CTS CPVC systems of fittings, pipe, supply stops & valves are Certified lead-free by NSF International (NSF®) for compliance with California and Vermont low-lead plumbing requirements for safe use in drinking water systems. Approved by national, state and municipal building codes*, Spears® CTS CPVC products are ideally suited for hot and cold water distribution systems in residential and commercial structures, as well as recreational vehicles, modular homes and mobile homes.

*Check state and local codes.

Full Line of CTS CPVC Fittings, Pipe, Supply Stops & Ball Valves 1/2" Through 2" Plus Supplemental IPS CPVC in 2-1/2" & Up

EverTUFF® CPVC pipe and fittings are available for most any size project using Copper Tube Size (CTS) in sizes 1/2" through 2". EverTUFF® Schedule 40 and Schedule 80 CPVC Iron Pipe Size (IPS) are available for sizes 2-1/2" and larger for commercial applications such as multi-story installations when adequate design and installation practices have been utilized.

Exceptional Corrosion Resistance

Unlike metal systems, CPVC products never rust, scale, or pit, and will provide many years of maintenance-free service and extended system life.

Energy Savings

Low heat conductivity minimizes heat loss in hot water systems.

Higher Flow Capacity

Smooth interior walls result in lower pressure loss and higher volume than conventional metal systems.

Lower System Costs

Lower material costs than metallic systems, combined with lighter weight and ease of installation, can substantially reduce overall system cost.

Suitable for Commercial Hot Water

CTS CPVC products can handle fluids at service temperatures up to 180°F (82°C). IPS CPVC service temperatures and pressures vary according to pipe size.

CTS CPVC 1/4-Turn Angle Supply Stop



Spears® EverTUFF® lead-free Supply Stops are used at plumbing fixtures to terminate hot and cold water supply. NSF® Certified to ASTM F 1970 for use in ASTM D 2846 Hot & Cold Water Distribution Systems rated to 100 psi @ 180°F Available in 1/2" CTS Socket or Spears® patented Special Reinforced (SR) 1/2" FIPT female thread inlet x 1/2" straight male thread outlet for connection to conventional 1/2" FPT faucet or toilet supply lines with captive seals.

CTS CPVC Ball Valves



Spears® EverTUFF® lead-free Copper-Tube-Size Ball Valves feature one-piece design that never requires adjustment. Standard EPDM O-ring seal and PTFE Seats enable bubble-tight shut off. High impact Polypropylene handle has double stop engagement. 100 psi maximum internal pressure rating at 180°F and NSF® Certified for use in potable water systems.



Spears® EverTUFF® Exclusive Specialty Fittings...

Gasket Sealed Brass-Threaded Transition Fittings



- Eliminates Radial Stress
- Requires NO Thread Sealants
- Eliminates Sealant Incompatibility
- NSF® Certified Lead-Free

Spears® lead-free Gasket-Sealed CTS CPVC Brass-Threaded Transition Fitting design features a special molded-in-place Brass Thread Insert fitted with an elastomer gasket seal at the base of the threads. The gasket sealed design eliminates radial stress and requires no thread sealant.

Special Reinforced (SR) Plastic Threaded Transition Fittings



- Eliminates Split Threads
- Eliminates Leaks Associated with Over and Under Tightening
- Eliminates MIC, Electrolytic & Soil Chemistry Corrosion Problems

Spears® lead-free Patented CTS CPVC Special Reinforced (SR) Fittings reduce problems associated with over tightening of female plastic pipe threads. Not just an added ring, this unique precompression design compensates for expansion forces generated from tapered pipe thread joint make-up.

Anti-Stress Drop-Ear Fittings & Brackets



Drop Ear 90° Elbow

- Secures plumbing drops against horizontal and vertical movement
- Eliminates fitting damage during installation of plumbing drops



Drop Ear Bracket

Spears® EverTUFF®, The Full-Service CTS CPVC Product Line...

Application

Spears® EverTUFF® Copper-Tube-Size (CTS) products are manufactured from chlorinated polyvinyl chloride (CPVC) for use with SDR-11 piping systems of CTS outside diameter in hot and cold water distribution systems in nominal pipe size 1/2" through 2". CTS CPVC products can be used in conjunction with Spears® supplemental Schedule 40 and Schedule 80 CPVC Iron-Pipe-Size (IPS) pipe and fittings for sizes 2-1/2" through 12" in commercial multi-story installations. Check state and local codes for application and restrictions.

Working Pressure

Spears® EverTUFF® CTS CPVC fittings, pipe and valves have a continuous working pressure rating of 100 psi at 180°F.

Conformance Standards

Spears® EverTUFF® CTS CPVC fittings conform to ASTM D 2846 Specification for Chlorinated Poly (Vinyl Chloride) (CPVC) Plastic Hot and Cold Water Distribution Systems.

Product Certification

Spears® EverTUFF® CTS CPVC pipe and fittings are certified by NSF International (NSF®) to ASTM D 2846 for use in Hot and Cold Water Distribution Systems, to the Uniform Plumbing Code (NSF® U.P.Code) and for use in potable water service. All Spears® EverTUFF® CTS CPVC products are NSF® certified lead-free in accordance with ANSI/NSF® Standard 61, Annex G for compliance with California's Health & Safety Code Section 116875 (commonly known as AB1953) and Vermont Act 193.

Sample Engineering Specifications

All fittings, supply stops and valves shall be Copper-Tube-Size (CTS) constructed from CPVC Type IV Cell Classification 23447. All CTS CPVC products shall be produced to applicable requirements of ASTM D 2846 and rated to 100 psi at 180°F, unless specifically designated for cold water service only. All supply stops shall be 1/4 turn angle pattern CTS CPVC with male thread outlets. All ball valves shall be CTS CPVC sealed unit type with EPDM O-ring and double stop Polypropylene handle. All CTS CPVC products shall be certified lead-free for potable water use by NSF International in accordance with NSF®-61 Annex G, as manufactured by Spears® Manufacturing Company.



CPVC CTS FITTINGS & VALVES

The information contained in this publication is based on current information and Product design at the time of publication and is subject to change without notification. Our ongoing commitment to product improvement may result in some variation. No representations, guarantees or warranties of any kind are made as to its accuracy, suitability for particular applications or results to be obtained therefrom. For verification of technical data or additional information not contained herein, please contact Spears® Technical Services Department [West Coast: (818) 364-1611 — East Coast: (678) 985-1263].

Application

Spears® Copper Tube Size (CTS) Pipe and Fittings are manufactured from chlorinated polyvinyl chloride (CPVC) for use with SDR 11 piping systems of CTS outside diameter in hot and cold water distribution systems. Check state and local codes for application and restrictions.

Conformance Standards

Spears® CPVC CTS Pipe and Fittings conform to ASTM D 2846 Specification for Chlorinated Poly (Vinyl Chloride) (CPVC) Plastic Hot and Cold Water Distribution Systems.

Working Pressure

Spears® CPVC CTS Pipe and Fittings have a continuous working pressure rating of 100 psi at 180°F (400 psi at 73°F).

Product Certification

Spears® CPVC CTS Pipe, Fittings and Special Reinforced (SR) Threaded transition adapters are tested and certified by the National Sanitation Foundation (NSF®) to ASTM D 2846 for use in Hot and Cold Water Distribution Systems, and for safe use in potable water systems under NSF® Standard 14/61.

All Spears® CPVC CTS Pipe and Fittings for CPVC Plastic Hot and Cold Water Distribution Systems in this manual are certified Lead-Free by NSF International under NSF® Standard 61, Annex G. The annex certifies compliance to California California's Health & Safety Code Section 116875 (commonly known as AB1953) and Vermont Act 193. Lead free is defined by these requirements as containing no more than a weighted average lead content of <=0.25%.

Testing

Once the system has been installed and allowed to cure properly, the system shall be tested in accordance with applicable code requirements. When testing with water (hydrostatic testing), the system must be slowly filled with water and the air bled from the highest and furthest points in the system before test pressure is applied. Failure to do so can cause damage to the piping system and could be harmful to the job site personnel should a failure occur. If a leak is found, the affected product must be cut and discarded. A new section can be installed using couplings or other approved means.

PURPOSE OF THIS MANUAL

This manual is intended for use by specifiers, installers, and users in the selection, design, installation, and inspection of CPVC systems installed using Spears® CPVC products. All information contained within this manual is considered vital to obtain proper system performance and must be read and fully understood before attempting to install these products. If you have any questions about the safe and proper installation of these products, contact Spears® Manufacturing Company 15853 Olden Street, Sylmar CA 91342 USA, Telephone (818) 364-1611 • (800) 862-1499.

HAZARD IDENTIFICATION

Definitions for identifying the various hazard levels are provided below.



This safety alert symbol indicates important safety messages. When you see this symbol, be alert to the possibility of personal injury. Carefully read and fully understand the message that follows.

⚠ DANGER

The use of the word "DANGER" identifies an immediate hazard with a likelihood of severe personal injury or death if instructions, including recommended precautions, are not followed.

⚠ WARNING

The use of the word "WARNING" identifies the presence of hazards or unsafe practices that could result in severe personal injury if instructions, including recommended precautions, are not followed.

⚠ CAUTION

The use of the word "CAUTION" identifies possible hazards or unsafe practices that could result in personal injury, product damage, and/or property damage if instructions, including recommended precautions, are not followed.

NOTICE

The use of the word "NOTICE" identifies special instructions that are important but not related to hazards.

CPVC CTS FITTINGS & VALVES



INSTALLER SAFETY INSTRUCTIONS

Read and understand this manual before proceeding with the installation and testing of the Spears® CPVC system. Education and a complete understanding of the instructions provided are requirements for the installer of the Spears® CPVC system. These instructions contain important information. If you need additional copies of this manual, or if you have any questions about the safe installation and use of this system, contact Spears® Manufacturing Company 15853 Olden Street, Sylmar CA 91342 USA, Telephone (818) 364-1611 • (800) 862-1499.

1. Inspect the product. Make sure all parts are included with the shipment and that all necessary tools are available for proper installation.
2. Wear safety glasses, hard hat, and foot protection.
3. Avoid dangerous environments. If using electrically powered tools for installation, make sure the area is free from moisture or wetness that could create unsafe working conditions. Keep work areas well lit. Allow sufficient space for measuring and dry-fitting the system.
4. Prevent back injury. Always practice safe lifting and installation techniques.
5. Use only tools specifically designed for plastic pipe and fittings.
6. Work in a well-ventilated area. Ensure that there is proper ventilation when applying primers and cements and/or soldering materials.
7. Wear protective gloves. PVA-coated protective gloves are recommended when applying solvent cement. If hands contact solvent cement, use a waterless, abrasive soap to remove all residue.
8. When solvent cementing, avoid sources of heat or open flame. **DO NOT** smoke while handling solvent cement.
9. Keep work areas clean. Cluttered areas and slippery floors can create hazardous working conditions.
10. Wear hearing protection. Protect your hearing if you are exposed to long periods of very noisy job-site operations.
11. Keep visitors away. All visitors should be kept a safe distance away from the work area.
12. Follow all manufacturers' recommended precautions when cutting or sawing pipes, or when using any heat, flame, or power tools.

MODEL CODES

Spears® CPVC products meet ASTM D 2846 requirements, as referenced in the current version of the following model codes.

Code	Organization
BOCA National Plumbing Code	Building Officials and Code Administrators International, Inc.
CABO 1- and 2-Family Dwelling Code	Council of American Building Officials
Canadian Plumbing Code	National Research Council, Canada
International Plumbing Code	BOCA, ICBO, SBCCI
National Standard Plumbing Code	National Association of Plumbing-Heating-Cooling Contractors
Standard Plumbing Code	Southern Building Code Congress International Inc.
Uniform Plumbing Code	International Association of Plumbing and Mechanical Officials

LISTING AGENCIES

Standard	Organization
Standards 14 and 61	NSF International (ANSI/NSF®)



CPVC CTS FITTINGS & VALVES

HANDLING AND STORAGE

Spears® CPVC products resist attack from a large group of chemicals that are corrosive to metallic piping. However, care must be taken to avoid contact with chemicals that are harmful to CPVC. Specific chemicals, or chemical vapors, that contact CPVC can weaken or damage the system. Consult with Spears® before using these CPVC products with any questionable materials.

⚠ WARNING

- **DO NOT** expose Spears® CPVC products to edible oils, esters, ketones, or petroleum-based products, such as: cutting oils; packing oils; traditional pipe thread paste or dopes; and certain lubricants. Consult with Spears® before using certain chemicals with these CPVC products.

Failure to follow this instruction could cause product/system damage, resulting in serious personal injury and/or property damage.

Spears® recommends that CPVC products be stored indoors. If storing outdoors, these products must be covered with a non-transparent material to prevent extended sunlight exposure. Brief exposure to direct sunlight on the job site may result in color fade, but it will not affect the material's physical properties. Spears® CPVC fittings should be stored in their original containers to keep them free from dirt and to help reduce the possibility of damage.

⚠ WARNING

- Spears® CPVC products must not be subjected to prolonged sunlight exposure.
- For outdoor storage, products must be stored in their original shipping containers, or they must be covered with a non-transparent material.

Failure to follow this instruction could cause product/system damage, resulting in serious personal injury and/or property damage.

Reasonable care must be exercised in handling Spears® CPVC products. Do not drop these products or allow anything to drop on them. If improper handling results in scratches, splits, or gouges, the damaged fitting or section of piping must be discarded.

SYSTEM LISTINGS, USAGE, AND STANDARDS

Penetrating Fire-Rated Walls and Partitions

Spears® CPVC products can be used within fire-rated buildings, provided all penetrations of fire barriers are constructed so that the fire rating of the barrier is not compromised. Most codes accept penetration sealing systems or devices that are UL Listed or have passed the appropriate ASTM E 119 or E 814 tests. The PPFA manual, "Plastic Pipe in Fire Restrictive Construction" (NER370), provides more information and lists the applicable test reports. In addition, reference can be made to the current issue of the "Underwriters Laboratories Inc. Directories of Fire Resistance – Vol. II" or the "WHI Certification Listings." Before starting an installation, always consult the building codes and local authority having jurisdiction.

⚠ WARNING

- Some fire-stopping systems contain chemicals that can damage CPVC products. Always consult with Spears® and the fire-stop manufacturer concerning compatibility with CPVC products.

Failure to follow this instruction could cause product/system damage, resulting in serious personal injury and/or property damage.

Underslab Installations

Spears® CPVC products are approved for underslab installations (with joints) in all model-plumbing codes. When performing underslab installations, it is important to support the pipe evenly on a smooth surface. The bedding and backfill should be sand or clean soil that is free from sharp rocks and other debris that could damage the pipe.

Underslab installations that contain joints must be pressure tested before pouring the slab. **NOTE:** IAPMO IS 2098, "Installation Standard for CPVC Solvent Cemented Hot and Cold Water Distribution Systems," requires a test at 150 psi for 2 hours. The pipe should be sleeved where it penetrates the slab, along with construction joints within the slab.

Spears® CPVC products can be used with pipe manufactured in accordance with ASTM D 2846, which is available in coils for underslab installations. When turning coiled piping up through a slab, into walls, etc., make sure the piping does not kink. Sections of pipe that contain kinks must be cut out and replaced.

Freeze Protection/Sunlight Exposure

CPVC piping must be protected from freezing in all installation locations. Attention shall be paid to local insulating techniques and codes that require a particular method. Use only methods and materials suitable for use with CPVC piping. Where freezing is not an issue, CPVC shall not be installed so as to be subject to direct sunlight after installation and not installed on the surface of a building, unless protected by a covering or a chemically compatible paint, such as water based Latex.

Hose Bibb Installation

Hose bibbs are to be connected only to metal system components which are adequately anchored to the building structure. CPVC plastic systems must terminate in the wall.

Water Heater Connections

Before attempting to use Spears® CPVC products in water heater connections, determine if local plumbing codes contain detailed requirements for connections to gas or electric storage-type heaters. **DO NOT** use Spears® CPVC products with commercial-type, non-storage water heaters.

For areas where local plumbing codes do not have requirements, the following information can be used as a guide for water heater connections:

- On electric water heaters, CPVC can be joined directly to the heater, using metal-to-CPVC transition fittings.
- On high-efficiency gas water heaters that use plastic vent piping, CPVC can be joined directly to the heater in the same way as an electric water-heater connection.
- On all other gas water heaters, there should be at least 6" of clearance between the exhaust flue and any CPVC piping. A minimum of 6" metallic pipe should connect directly to the heater so that the CPVC piping cannot be damaged by the buildup of excessive, radiant heat from the flue.
- A temperature/pressure relief valve should be installed so that the sensing element contacts the water at the top of the heater.
- Spears® CPVC products are approved by all model codes for use as relief-valve drain lines. A metal-to-CPVC transition fitting should be used to connect the piping to the relief valve. Then, the piping should be continued to the outlet. Both horizontal and vertical pressure relief drain should be supported every 3 feet.
- For horizontal runs, slope the piping toward the outlet. Support the piping at 3-foot centers or closer. The piping must discharge to the atmosphere at an approved location.
- Instantaneous water heaters (i.e., under sink units) require at least 6" of metallic pipe connected to heater inlet and no CPVC installed down stream.

BASIC JOINT ASSEMBLY

Cutting the Pipe

CPVC piping can be cut easily with a ratchet cutter, wheel-type plastic piping cutter, a power saw, or any other fine-tooth saw.

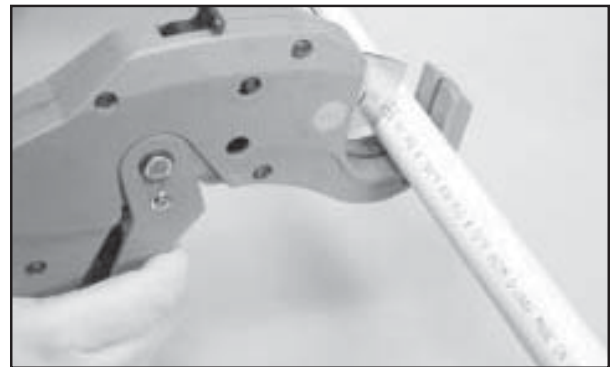

Be careful not to split the pipe if using a ratchet-type cutter, especially in temperatures below 50°F. If any damage or cracking is evident, cut off at least 2" of the pipe beyond any visible crack.

It is important that the cutting tools being used are designed for plastic piping. To ensure that the pipe is cut square, use a miter box when cutting the pipe with a saw. Cutting the pipe as square as possible provides the maximum bonding surface area.



CPVC CTS FITTINGS & VALVES

Deburring

Burrs and filings can prevent contact between the pipe and the fitting during assembly and must be removed from the outside and the inside of the pipe. A chamfering tool or file is suitable for this purpose (refer to photos below).



A slight bevel must be placed at the end of the pipe, as shown below. A slight bevel will ease the entry of the pipe into the socket and minimize the chance of cement being wiped off the fitting.

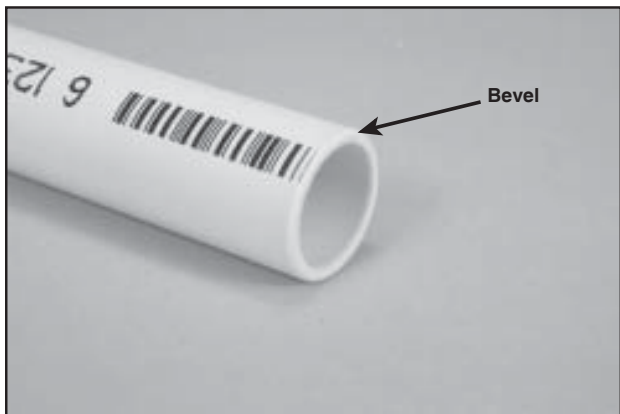

Fitting Preparation

Using a clean, dry rag, wipe any loose dirt and moisture from the fitting's socket and pipe end. Moisture can slow the cure time, and at this stage of assembly, excessive moisture can reduce joint strength.

⚠ WARNING

- Before assembling any Spears® CPVC products, inspect all components for cuts, scratches, gouges, split ends, or any other irregularities that have occurred during shipping and handling.
- Failure to follow this instruction could cause joint/system failure, resulting in serious personal injury and/or property damage.

Check all mating components to ensure that tolerances and engagements are compatible. **DO NOT** use any components that appear irregular or do not fit properly. Contact Spears® regarding any questions about usability.

Check the dry fit of the pipe and fitting. The pipe should enter the fitting's socket easily 1/4 - 3/4 of the way.

⚠ WARNING

- Always apply a second coat of cement to the pipe for joints that are 1-1/4 inch and larger.
- Failure to follow these instruction could cause joint/system failure, resulting in serious personal injury and/or property damage.

SOLVENT CEMENTING PROCEDURES

Verify the expiration date located on the solvent cement container. The cement can be used for a period of 2 years from the date stamped on the container. When cementing pipe and fittings in extremely cold temperatures, make sure the cement has not "JELLED." Jelled or expired cement must be discarded in an environmentally friendly fashion, in accordance with local regulations. To prolong the life of solvent cement, keep the containers tightly closed when not in use, and cover the container as much as possible during use. If an unopened solvent cement container is subjected to freezing temperatures, the cement may become extremely thick. Place the closed container in a room temperature area where, after a short time period, the cement will return to a usable condition. **DO NOT** attempt to heat solvent cement.

⚠ WARNING

- Before assembling any Spears® CPVC products, verify that the solvent cement is within 2 years of the date stamped on the can and that it does not have a "JELLED" appearance. Jelled or expired solvent cement will not provide the strength needed to make a proper joint.
- Failure to follow these instructions could cause joint/system failure, resulting in serious personal injury and/or property damage.

The cement must be applied when the pipes and fittings are clean and free from any moisture and debris.

USING AN APPLICATOR OR NATURAL BRISTLE BRUSH THAT IS AT LEAST 1/2 THE SIZE OF THE PIPE DIAMETER, WORK THE CEMENT INTO THE JOINING SURFACES USING A CONTINUOUS, CIRCULAR MOTION.

Apply the cement in the following sequence, as pictured below:

1. Apply a coat to the pipe
2. Apply a coat to the fitting
3. Apply a second coat to the pipe, if required

Avoid puddling the cement on or within the fitting and pipe. Puddled cement causes excess softening and damage to the CPVC material.



Apply a heavy, even coat of cement to the outside of the pipe end. Work the cement into the joining surfaces using a continuous, circular motion.



Apply a medium coat to the fitting socket. Avoid getting cement in other sockets or threaded connections.

A second application of cement must be applied to the pipe end if a 1-1/4 inch and larger joint is being prepared.

⚠ WARNING

- Always apply a second coat of cement to the pipe for joints that are 1-1/4 inch and larger.
 - Avoid puddling the cement on the pipe or within the fitting.
 - Avoid getting cement into other sockets or threaded connections.
- Failure to follow these instructions could cause joint/system failure, resulting in serious personal injury and/or property damage.

Joint Assembly

Immediately insert the pipe into the fitting's socket while rotating the pipe 1/4 turn. Align the fitting in the proper orientation at this time. Make sure the pipe bottoms out at the fitting's stop.

Hold the assembly for 10 to 15 seconds to ensure initial bonding occurs. A bead of cement must be present around the pipe and fitting juncture. If this bead is not continuous around the socket's shoulder, insufficient cement was applied.

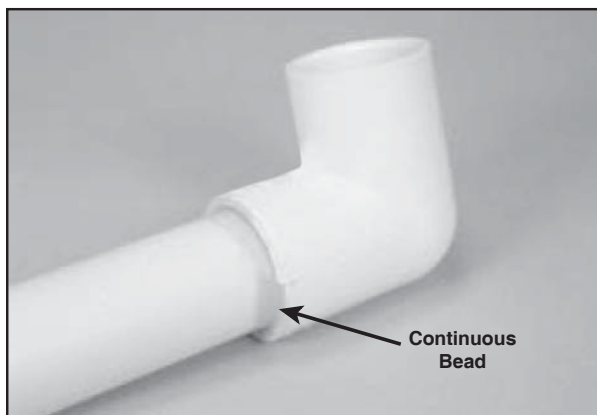

If insufficient cement was applied, the joint must be cut out and discarded, and a new joint must be assembled.

Any cement, in excess of the bead, can be wiped off with a dry, clean rag.

Set and Cure Times

- The set and cure times for CPVC solvent cement depend on pipe size, temperature, relative humidity, and tightness of fit. Drying time is faster for drier environments, smaller pipe sizes, high temperatures, and tighter fits.
- Special care must be taken when assembling Spears® CPVC products in low temperatures (below 40°F) or high temperatures (above 80°F).
- Extra set and handling times must be allowed in colder temperatures. When cementing pipe and fittings in cold temperatures, make sure the cement has not "JELLED." Jelled cement must be discarded.
- In higher temperatures, make sure both surfaces to be joined are still wet with cement during assembly.
- The assembly must be allowed to set, without any stress on the joint, for 5 minutes.
- Following the initial set period, the assembly can be handled carefully by avoiding stress on the joint.

Refer to the following table for minimum cure times before pressure testing.



CPVC CTS FITTINGS & VALVES

MINIMUM CURE TIMES FOR SOLVENT CEMENT BEFORE PRESSURE TESTING

150-psi Maximum Test Pressure

Piping Size	Ambient Temperature During Cure (Relative Humidity 60% or Less)		
	60°F to 100°F	40°F to 60°F	0°F to 40°F
Nominal Diameter inches			
1/2	15 minutes	20 minutes	30 minutes
3/4	15 minutes	20 minutes	30 minutes
1	15 minutes	20 minutes	30 minutes
1-1/4	15 minutes	20 minutes	30 minutes
1-1/2	30 minutes	45 minutes	1 hour
2	30 minutes	45 minutes	1 hour

⚠ WARNING

- Make sure the cement is allowed to cure, according to the times listed in the chart, for the pipe size and ambient temperature.
- Failure to follow this instruction could cause joint/system failure, resulting in serious personal injury and/or property damage.

TRANSITION JOINTS AND FITTINGS

CPVC pipe can be connected to copper, brass, valves, and other materials using a variety of transition fittings including unions, compression fittings, specially reinforced male and female adapters, flanged joints, grooved joints and other readily available transition fittings.

Do not thread CPVC pipe and do not use regular CPVC female threaded fittings. Regular CPVC male threaded fittings shall only be used on cold water applications. Spears® Special Reinforced Male Adapters, CPVC Lined Brass-Threaded Male Adapters, Special Reinforced Female Adapters and Gasket Sealed Brass-Threaded Female Adapters are recommended for hot water applications and threaded transitions to metal pipe. All approved threaded CPVC joints must be accessible. (See also Water Heater Connections section for additional installation details.)

Standard compression fittings with brass ferrules can be used; however, PTFE tape must be applied over the brass ferrule to compensate for the dissimilar thermal expansion rates between the brass and CPVC. Caution must be exercised to prevent over tightening of compression fittings. Use extreme care when soldering any metal system to prevent flame contact with or heat distortion in CPVC pipe and fittings.

Assembling Gasket Sealed Brass-Threaded Female Adapter Connections

Threaded connections using Spears® Gasket Sealed Brass-Threaded Female Adapters with O-ring seal at the base of the fitting thread are designed to be assembled without thread sealants. **DO NOT** use ANY thread sealants, tape or paste, in these joints. Thread hand tight and tighten snug. This produces a leak-free, reliable seal without problems associated with incompatible thread pastes or improperly applied tape (TFE) sealants.

⚠ WARNING

- **DO NOT** use ANY thread sealants on Gasket Sealed Brass-Threaded Female Adapter. Sealants, especially tape (TFE), may prevent proper joint make-up and result in leaks.
- **DO NOT** over tighten. Wrench over tightening of joints may result in fitting damage.

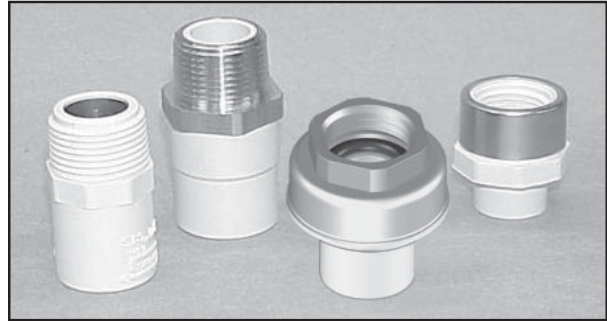

Assembling Standard Threaded Connections

Threaded connections using standard tapered threads (including Spears® Special Reinforced Female Adapters, Special Reinforced Male Adapters, Brass-Threaded and Regular Male Adapters) require the application of a thread sealant that is compatible with CPVC material. Spears® recommends the use of Spears® Blue 75 Thread Sealant. **DO NOT** use ANY thread sealants on Spears® Gasket Sealed Brass-Threaded Female Adapters (see above).

⚠ WARNING

- Use only thread sealants recommended by Spears®. Other joint compounds or pastes may contain substances that could cause stress cracks in CPVC or brass materials.
- Failure to follow these instructions could cause joint/system failure, resulting in serious personal injury and/or property damage.

Apply sealant to the male threads only. Make sure all threads are covered. **DO NOT** clog the waterway with excess sealant.

If PTFE tape is used, Spears® recommends a thickness of at least .0025" that meets or exceeds military specification, MIL-T-27730A. **DO NOT** use a combination of tape and thread sealant on the same joint.

Apply PTFE tape in the direction of the threads by starting with the first full thread and continuing over the entire thread length. Make sure all threads are covered. Generally, 2 - 3 wraps are sufficient to produce a watertight connection.

⚠ WARNING

- **DO NOT** use more than five wraps of PTFE tape. Excessive tape can cause bunching, resulting in fractures of the plastic fitting or the brass insert due to excessive hoop stress.
- Failure to follow these instructions could cause joint/system failure, resulting in serious personal injury and/or property damage.

DO NOT over-torque any threaded connections. Generally, one to two turns beyond finger-tight are required for a threaded connection. Factory testing has indicated that 10 - 25 ft-lbs of torque is adequate to obtain a leak-free seal. Use only a smooth-jawed wrench or strap wrench when installing threaded connections.



⚠ WARNING

- Tools with teeth **MUST NEVER** be applied to any part of a CPVC fitting. The teeth can damage and weaken CPVC material.
- Failure to follow these instructions could cause joint/system failure, resulting in serious personal injury and/or property damage.

ENGINEERING DATA SECTION

Pipe and Fitting Specifications

CPVC pipe is produced in SDR 11 dimensions using copper tube size (CTS) outside diameters, as specified in ASTM D 2846. Spears® fittings are produced in SDR 11 dimensions, in accordance with ASTM D 2846. The combined pipe and fitting system is NSF listed for potable water. In addition, the system meets test requirements of the Uniform Building Code.

SDR 11 (Ref. ASTM D 2846)			Weight lbs/ft
Size Nominal inches	Average OD inches	Average ID inches	
1/2	0.625	0.469	.090
3/4	0.875	0.695	.149
1	1.125	0.901	.240
1-1/4	1.375	1.105	.353
1-1/2	1.625	1.309	.489
2	2.125	1.716	.829

Pressure Ratings

The Spears® CPVC system, including the joint, has a continuous rated working pressure of 100 psi at 180°F or 400 psi at 73°F. CPVC systems have the capability to withstand short-term temperature/pressure increases above 100 psi at 180°F, as evidenced by their ability to consistently surpass the 48 hour, 150 psi Uniform Building Code test at 210°F. CPVC pipe should not be used where temperatures will consistently exceed 180°F.

Pressure-Temperature De-Rating Factors For CTS CPVC 4120 SDR 11 Piping Systems

°F	Factor	Rating, PSI
73	1.00	400
80	1.00	400
90	0.91	360
100	0.82	325
120	0.65	260
140	0.50	200
160	0.40	160
180	0.25	100

The pressure de-rating factor is the same for all pipe sizes.

Example: Determine the maximum allowable operating pressure for a CTS CPVC piping system with an operating temperature of 140°F. Using de-rating factor of 0.50 for 140° From the above chart, the maximum allowable operating pressure = 400 x 0.50 = 200 psi.

Hydraulic Design

Friction Loss – Friction loss through CPVC pipe is most commonly obtained by the use of the Hazen-Williams equations as expressed below for water:

$$f = .2083 \times \frac{(100)^{1.852}}{C} \times \frac{G^{1.852}}{di^{4.8655}}$$

where:

f = friction head of feet of water per 100' for the specific pipe size and I.D.

C = a constant for internal pipe roughness. 150 is the commonly accepted value for CPVC pipe.

G = flow rate of gallons per minute (U.S. gallons).

di = inside diameter of pipe in inches.

Compared to other materials on construction for pipe, thermo-plastic pipe smoothness remains relatively constant throughout its service life.

Flow Velocities – Velocities for water in feet per second at different GPM's and pipe inside diameters can be calculated as follows:

$$V = .3208 \frac{G}{A}$$

where:

V = velocity in feet per second

G = gallons per minute

A = inside cross sectional area in square inches

While these systems can operate with flow velocities in excess of 10 feet per second, a maximum of 8 feet per second velocity is recommended to extend system life.

The following table lists Friction Loss and Flow Velocities for SDR 11 CTS CPVC Pipe at different flow rates.



CPVC CTS FITTINGS & VALVES

FRICTION LOSS AND FLOW VELOCITY FOR SDR 11 CTS CPVC PIPE

Friction head and friction loss are per 100 feet of pipe.

Gallons Per Minute	1/2 in.	Pressure Loss PSI Per 100 Ft.	1.38	5.00	10.59	18.04	27.27	38.23	50.86	65.13	81.00	98.45	
		Head Loss Feet of Water Per 100 Ft.	3.19	11.53	24.43	41.62	62.91	88.12	117.32	150.23	186.85	227.11	
		Velocity Feet Per Second	1.71	3.42	5.13	6.83	8.54	10.25	11.96	13.67	15.38	17.08	
	3/4 in.	Pressure Loss PSI Per 100 Ft.	0.22	0.50	0.79	1.16	1.67	2.28	3.02	3.90	4.93	6.11	7.45
		Head Loss Feet of Water Per 100 Ft.	0.50	1.82	3.85	6.55	9.91	13.89	18.47	23.66	29.42	35.76	42.68
		Velocity Feet Per Second	0.80	1.60	2.40	3.20	4.00	4.79	5.59	6.39	7.19	7.99	8.78
	1 in.	Pressure Loss PSI Per 100 Ft.	0.06	0.15	0.23	0.49	0.83	1.25	1.76	2.34	2.99	3.72	4.52
		Head Loss Feet of Water Per 100 Ft.	0.15	0.53	1.12	1.91	2.89	4.05	5.39	6.90	8.58	10.43	12.45
		Velocity Feet Per Second	0.48	0.96	1.44	1.93	2.41	2.89	3.37	3.85	4.33	4.82	5.30
	1-1/4 in.	Pressure Loss PSI Per 100 Ft.	1.71	3.62	6.17	9.33	13.07	17.39	22.27	27.70	33.66	40.16	
		Head Loss Feet of Water Per 100 Ft.	3.94	8.35	14.23	21.51	30.15	40.11	51.37	63.89	77.66	92.65	
		Velocity Feet Per Second	3.23	4.84	6.46	8.07	9.68	11.30	12.91	14.52	16.14	17.75	
1-1/2 in.	Pressure Loss PSI Per 100 Ft.	0.76	1.61	2.74	4.15	5.81	7.73	9.90	12.31	14.96	17.85	20.97	
	Head Loss Feet of Water Per 100 Ft.	1.75	3.71	6.33	9.56	13.40	17.83	22.83	28.40	34.52	41.18	48.38	
	Velocity Feet Per Second	2.31	3.47	4.63	5.78	6.94	8.09	9.25	10.41	11.56	12.72	13.88	
2 in.	Pressure Loss PSI Per 100 Ft.	0.21	0.45	0.76	1.15	1.62	2.15	2.75	3.42	4.16	4.96	5.83	
	Head Loss Feet of Water Per 100 Ft.	0.49	1.03	1.76	2.66	3.73	4.96	6.35	7.89	9.60	11.45	13.45	
	Velocity Feet Per Second	1.35	2.03	2.70	3.38	4.05	4.73	5.40	6.08	6.75	7.43	8.10	
Gallons Per Minute	2 in.	Pressure Loss PSI Per 100 Ft.	0.21	0.45	0.76	1.15	1.62	2.15	2.75	3.42	4.16	4.96	5.83
		Head Loss Feet of Water Per 100 Ft.	0.49	1.03	1.76	2.66	3.73	4.96	6.35	7.89	9.60	11.45	13.45
		Velocity Feet Per Second	1.35	2.03	2.70	3.38	4.05	4.73	5.40	6.08	6.75	7.43	8.10
	2 in.	Pressure Loss PSI Per 100 Ft.	0.21	0.45	0.76	1.15	1.62	2.15	2.75	3.42	4.16	4.96	5.83
		Head Loss Feet of Water Per 100 Ft.	0.49	1.03	1.76	2.66	3.73	4.96	6.35	7.89	9.60	11.45	13.45
		Velocity Feet Per Second	1.35	2.03	2.70	3.38	4.05	4.73	5.40	6.08	6.75	7.43	8.10
	2 in.	Pressure Loss PSI Per 100 Ft.	0.21	0.45	0.76	1.15	1.62	2.15	2.75	3.42	4.16	4.96	5.83
		Head Loss Feet of Water Per 100 Ft.	0.49	1.03	1.76	2.66	3.73	4.96	6.35	7.89	9.60	11.45	13.45
		Velocity Feet Per Second	1.35	2.03	2.70	3.38	4.05	4.73	5.40	6.08	6.75	7.43	8.10
	2 in.	Pressure Loss PSI Per 100 Ft.	0.21	0.45	0.76	1.15	1.62	2.15	2.75	3.42	4.16	4.96	5.83
		Head Loss Feet of Water Per 100 Ft.	0.49	1.03	1.76	2.66	3.73	4.96	6.35	7.89	9.60	11.45	13.45
		Velocity Feet Per Second	1.35	2.03	2.70	3.38	4.05	4.73	5.40	6.08	6.75	7.43	8.10

CPVC CTS FITTINGS & VALVES



Hanger/Support Spacing

Since CPVC pipe is rigid, it requires fewer supports than flexible, plastic systems.

Vertical runs should be supported at each level so that the weight of the run is not placed on a fitting or a joint.

Horizontal runs require support every 3 feet for 1/2" - 1" diameter pipe and every 4 feet for 1-1/4" and larger diameters. Support spacing should be in accordance with applicable local codes.

Horizontal runs must be braced so that the stress loads (caused by bending or snaking) will not be placed on a fitting or a joint. Hanger support spacing information is shown in Table A.

Spears® recommends that hangers, designed for supporting CPVC, be used to support CPVC piping. However, some hangers, designed for steel pipe, may be used if their suitability is clearly established. These hangers must be selected to accommodate the specific pipe size. In addition, they cannot contain rough or sharp edges that contact the pipe, and they must not bind the pipe from axial movement that is caused by expansion and contraction.

**Table A - Hangers and Supports
Reference CPVC ASTM D 2846 Systems**

Pipe Size (CTS) Nominal inches	Maximum Support Spacing Feet	Water-filled Weight lbs/ft
1/2	3	0.153
3/4	3	0.294
1	3	0.486
1-1/4	4	0.726
1-1/2	4	1.014
2	4	1.733

⚠ WARNING

Horizontal runs and vertical risers of CPVC piping require additional support and provision for expansion and contraction, compared to metal piping systems. Systems must be designed and installed by qualified personnel, in accordance with the properties and capabilities of the material.

Failure to follow these instructions could cause joint or system failure, resulting in serious personal injury and/or property damage.

Material Properties

**Table I
Modulus of Elasticity and Stress vs. Temperature**

Property	Temperature °F							
	73	80	90	100	110	120	140	150
Modulus of Elasticity "E" x 10 ⁵ psi	3.900	3.840	3.780	3.700	3.460	3.210	3.050	2.840
Working Stress "S" psi	1900	1785	1630	1485	1345	1270	950	875

**Table II
Physical and Thermal Properties**

Property		CPVC	ASTM
Specific Gravity	"Sp. Gr."	1.51	D 792
IZOD Impact Strength (ft-lbs/inch of notch)		5.0	D 256A
Modulus of Elasticity, psi	"E"	3.9 x 10 ⁵	D 638
Ultimate Tensile Strength, psi		8,000	D 638
Compressive Strength, psi	"σ"	9,000	D 695
Poisson's Ratio	"ν"	.35 - .38	-
Working Stress @ 73°F, psi	"S"	1,900	D 1598
Hazen-Williams "C" Factor	"C"	150	-
Coefficient of Linear Expansion in/(in °F)	"e"	3.2 x 10 ⁻⁵	D 696
Thermal Conductivity BTU/(hr °F ft/in ²)	"k"	0.95	C 177
Upper Temperature Limit	"°F"	205	
Flammability		Flame Retardant	
Electrical Conductivity		Non-Conductor	



CPVC CTS FITTINGS & VALVES

Expansion and Contraction

⚠ WARNING

Horizontal runs and vertical risers of CPVC piping require additional support and provision for expansion and contraction, compared to metal piping systems. Systems must be designed and installed by qualified personnel, in accordance with the properties and capabilities of the material. Failure to follow these instructions could cause joint or system failure, resulting in serious personal injury and/or property damage.

Expansion Loop Offset Configurations

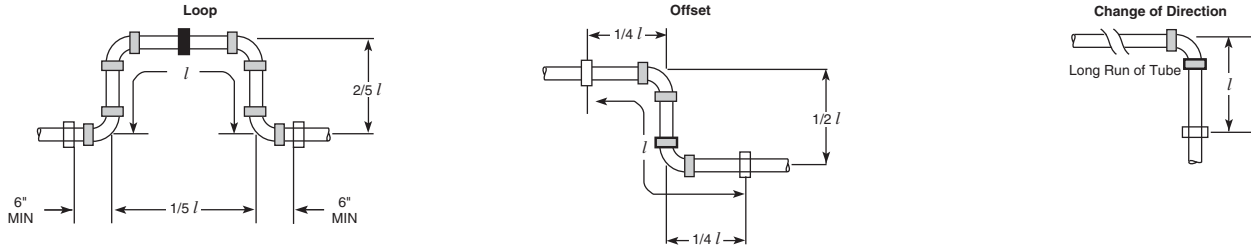

Hangers or guides should only be placed in the loop, offset or change of direction as indicated above. Piping supports should restrict lateral movement and should direct axial movement into the expansion loop.

CPVC, like all piping materials, expands and contracts with changes in temperature. The coefficient of linear expansion for CPVC is 3.2×10^{-5} in./in./°F. A 25°F change in temperature will cause an expansion of 1" for a 100-ft straight length. For most installation and operating conditions, expansion and contraction can be accommodated at changes of direction. Based on the following chart, an offset or loop is required on a long, straight run.

Table III: Thermal Expansion in inches

Temp Change ΔT °F	Length of Run in feet													
	5	10	15	20	25	30	35	40	45	50	70	90	120	160
	Thermal Expansion ΔL (inches)													
20	0.04	0.08	0.12	0.15	0.19	0.23	0.27	0.31	0.35	0.38	0.54	0.69	0.92	1.23
30	0.06	0.12	0.17	0.23	0.29	0.35	0.40	0.46	0.52	0.58	0.81	1.04	1.38	1.84
40	0.08	0.15	0.23	0.31	0.38	0.46	0.54	0.61	0.69	0.77	1.08	1.38	1.84	2.46
50	0.10	0.19	0.29	0.38	0.48	0.58	0.67	0.77	0.86	0.96	1.34	1.73	2.30	3.07
60	0.12	0.23	0.35	0.46	0.58	0.69	0.81	0.92	1.04	1.15	1.61	2.07	2.76	3.69
70	0.13	0.27	0.40	0.54	0.67	0.81	0.94	1.08	1.21	1.34	1.88	2.42	3.23	4.30
80	0.15	0.31	0.46	0.61	0.77	0.92	1.08	1.23	1.38	1.54	2.15	2.76	3.69	4.92
90	0.17	0.35	0.52	0.69	0.86	1.04	1.21	1.38	1.56	1.73	2.42	3.11	4.15	5.53
100	0.19	0.38	0.58	0.77	0.96	1.15	1.34	1.54	1.73	1.92	2.69	3.46	4.61	6.14

$\Delta L = 12 e l (\Delta T)$
 $e = 3.2 \times 10^{-5}$ in./in./°F (Coefficient of Linear Expansion – Table II)
 L = Length of Run in feet
 ΔT = Temperature Change in °F

Example: How much will a 40-ft run of 2" CPVC pipe expand if the expected ambient temperature will range from 45°F to 85°F?
 $\Delta L = 12 e l (\Delta T)$
 $\Delta L = 12 (.000032) \times 40 \times 40$
 $\Delta L = .61"$

Table IV: Expansion Loop Length in inches

Nominal Pipe Size	Avg. O.D.	Length of Run in feet													
		5	10	15	20	25	30	35	40	45	50	70	90	120	160
		Length of Loop (inches) Temperature Change (ΔT) = 100°F - 30°F = 70°F													
1/2	0.625	6	8	10	11	13	14	15	16	17	18	21	24	27	32
3/4	0.875	7	9	11	13	15	16	18	19	20	21	25	28	32	38
1	1.125	8	11	13	15	17	18	20	21	23	24	28	32	37	43
1-1/4	1.375	8	12	14	17	19	20	22	24	25	26	31	35	41	47
1-1/2	1.625	9	13	16	18	20	22	24	26	27	29	34	38	44	51
2	2.125	10	15	18	21	23	25	27	29	31	33	39	44	51	58

Note: Table IV is based on 70°F temperature change. Values rounded.

$$l = \sqrt{\frac{3ED(\Delta L)}{2S}}$$

l = Length of Expansion Loop in inches
 E = Modulus of Elasticity at 100°F (Table I)
 D = Average OD of Pipe
 ΔL = Change in Length of Pipe Due to Change in Temperature (Table III)
 S = Working Stress at 100°F (Table I)

CPVC CTS FITTINGS & VALVES



Example: How much expansion can be expected in a 200-ft run of 2" CPVC pipe? How long should the expansion loop be to compensate for the expansion (the expected temperature range will be from 40°F to 110°F)?

First Find:
 $\Delta T = (\text{Change in Temperature})$
 $\Delta T = T_2 - T_1$
 $\Delta T = 110^\circ\text{F} - 40^\circ\text{F}$
 $\Delta T = 70^\circ\text{F}$

To Find
 $\Delta L = (\text{Amount of Expansion in inches from Table III})$
 $\Delta L = \Delta L \text{ of } 160 \text{ ft with a } \Delta T \text{ of } 70^\circ\text{F} + \Delta L \text{ of } 40 \text{ ft. with a } \Delta T \text{ of } 70^\circ\text{F}$
 $\Delta L = 4.30" + 1.08"$
 $\Delta L = 5.38"$
— OR —
 $\Delta L = 12 eL (\Delta T)$
 $e = 3.2 \times 10^{-5}$ (from Table II)
 $L = \text{Length of Run in Feet}$
 $\Delta T = \text{Change in Temperature in } ^\circ\text{F}$
 $\Delta L = 12 \times 0.00032 \times 200 \times 70$
 $\Delta L = 5.38"$

$$l = \sqrt{\frac{3ED(\Delta L)}{2S}}$$

$l = \text{Length of Expansion Loop in inches}$
 $E = \text{Modulus of Elasticity at } 110^\circ\text{F (Refer to Table I)}$
 $D = \text{Average OD of Pipe}$
 $\Delta L = \text{Change in Length of Pipe Due to Change in Temperature}$
 $S = \text{Working Stress at } 110^\circ\text{F (Refer to Table I)}$

To find the length of the expansion loop or offset in inches:

$$l = \sqrt{\frac{3ED(\Delta L)}{2S}}$$

$l = \text{Length of Expansion Loop in inches}$
 $E = \text{Modulus of Elasticity at Maximum Temperature from Table I}$
 $D = \text{Average Outside Diameter of the Pipe from Table IV}$
 $S = \text{Working Stress at Maximum Temperature from Table I)}$
 $\Delta L = \text{Change in Length of Pipe Due to Change in Temperature from Table III}$

$$l = \sqrt{\frac{3 \cdot 346,000 \cdot 2.125 \times 5.38}{2 \times 1345}}$$

$$l = \sqrt{4412}$$

$$l = 66.4$$



CPVC CTS FITTINGS & VALVES

CPVC Piping System Guidelines for Commercial Hot & Cold Water Distribution Applications

EverTUFF® CPVC Systems provide highly sustainable, cost effective alternatives to metal piping in commercial multi-story applications for hot and cold water distribution. EverTUFF® CPVC pipe and fittings are available for most any size project using Copper Tube Size (CTS) CPVC in sizes 1/2" through 2" and in supplemental Schedule 40 and Schedule 80 CPVC Iron Pipe Size (IPS) for sizes 2-1/2" through 12".

EverTUFF® CPVC Systems meet applicable code requirements and are fully suitable for use in multi-story installations where adequate design and installation practices have been utilized. The following overview includes, but is not limited to, general considerations that *must* be addressed in all CPVC system designs and installations.

WARNING: Failure to follow proper industry established design and installation practices and requirements for CPVC systems may result in system failure, severe personal injury and/or property damage. The following are general guidelines for issues that must be addressed with use of CPVC in commercial water distribution systems. All design criteria applicable to thermoplastics should be reviewed and approved by a licensed engineering professional.

Product Capability & Ratings

EverTUFF® CPVC CTS piping is produced in Standard Dimensional Ratio (SDR) of 11, where the ratio of wall thickness to outside diameter of the pipe is a constant of 11. This produces the same pressure rating for all sizes.

Available Sizes: 1/2", 3/4", 1", 1-1/4", 1-1/2", 2"

Pressure Rating: 100 psi @ 180°F

Applicable Standard: ASTM D 2846 for CPVC Copper Tube Size (CTS) Hot & Cold Water Distribution Systems

Potable Water Certification: ANSI/NSF® Standard 61

EverTUFF® Industrial CPVC IPS piping produced in Schedule 40 or Schedule 80 dimensions can be used for larger pipe sizes. Pressure ratings will vary according to diameter and water temperature. The appropriate Schedule piping (40 or 80) must be selected according to application and system requirements.

Supplemental Available Sizes: 2-1/2", 3", 4", 6", 8", 10", 12"

Pressure Ratings: According to pipe size and temperature; specified in ASTM F 441

Applicable Standard: Pipe - ASTM F 441 for CPVC Schedule 40 & Schedule 80 Pipe

Fittings – ASTM F 439 for CPVC Schedule 80 Fittings

Potable Water Certification: ANSI/NSF® Standard 61

Piping Support & Spacing

Hanger and support spacing for horizontal runs of Spears® EverTUFF® CPVC piping varies according to pipe diameter and water temperature. Local code requirements generally affect minimum spacing for CPVC piping and must be verified. Additional support should be provided for valves, flanges, expansion joints or other sources of load concentration. Hangers and straps designed for CPVC should be used, but some hangers designed for steel pipe can be used if suitable. Use only smooth straps or hangers that do not place rough or sharp edges against the pipe. Do not anchor CPVC piping too tight to supports in order to allow movement caused by expansion and contraction, bind or restrict movement.

Vertical runs (risers) must be properly supported to prevent excessive loading on the lower fitting or other stress concentration areas. Maintain vertical piping in straight alignment with supports at each floor level, or at 10 feet (3.05 m) intervals, whichever is less. Hangers and clamps suitable for this purpose include riser clamps or double bolt type clamps that provide a floating system which allows pipe movement due to thermal expansion and contraction when installed. Clamps and hangers must not compress, distort, cut, abrade or exert compressive stresses on the pipe; the use of riser clamps that utilize compression to support the pipe weight are not recommended.

Wall Penetration

Where Spears® EverTUFF® CPVC pipe passes through metal studs, protection must be used to prevent abrasion and reduce noise. Plastic insulators, rubber grommets, pipe insulation or similar devices may be used for this purpose.

Where penetrations of fire barriers are required, Spears® EverTUFF® CPVC piping can be used with Fire-Stop penetration sealing systems approved for use with CPVC. Most codes accept penetration sealing systems or devices that are UL Listed or have passed the appropriate ASTM E 119 or E 84 tests. Before starting an installation, always consult the building codes and local authority having jurisdiction.

Thermal Expansion & Contraction

Expansion and contraction in CPVC thermoplastic systems differs significantly from that of metal systems and can result in major problems if not adequately considered. Spears® EverTUFF® CPVC piping will expand or contract about 1 inch per 50 feet of length with a 50-degree temperature change. This movement must be accommodated in system design or else a system can literally push or pull itself apart. Thermal expansion is a primary concern in hot water lines.

Expansion and contraction expectations must be calculated according to standard industry practices. For most installation and operating conditions, movement accommodation can be made at system changes of direction, through use of use of telescoping expansion joints, an offset or loop on a long straight runs. Telescoping expansion joint needs must be properly calculated and the telescoping units properly aligned and installed. While only one properly sized expansion loop is required in any straight run, two or more properly sized smaller expansion loops can be used to conserve space as required.



Hydraulic Design

Spears® EverTUFF® CPVC piping systems must be sized based on industry standard hydraulic calculations for factors such as friction loss and flow velocity. Surge protection must also be considered.

Friction loss through CPVC pipe is typically determined by the use of the Hazen-Williams equations with a C Factor (internal roughness) of 150. Friction loss and flow velocity tables are also available for both CTS CPVC and Schedule 40 or Schedule 80 IPS CPVC piping.

While hot and cold water CTS CPVC systems can operate with flow velocities of 8 feet per second. A maximum velocity of 5 feet per second is recommended for Schedule 40 or Schedule 80 IPS CPVC systems. System flow velocity should always be maintained close to 5 feet per second in mixed CTS/IPS CPVC systems. Hydraulic designs, and value engineered changes should always be reviewed by a licensed engineering professional.

System Connections

Proper system connections are critical to maintaining system integrity and reliability. It is essential that all installation personnel be thoroughly trained in joining methods.

Solvent Cement Joints are the primary method of making connections between CPVC components. Solvent cements specifically approved to ASTM F 493 for CPVC and for use with ASTM D 2846 systems should be used on CTS CPVC installations. ASTM Standards permit the use of "One-step" (primerless) cements; however, local codes must be checked since some require use of both a primer and cement in CPVC joints. Larger Schedule 40 or Schedule 80 IPS joints should be made using an ASTM F 493 approved CPVC cement and primer. Manufacturer's instructions for cement/primer application, initial set times and applicable cure time in accordance with pipe size and temperature must be followed. Proper sized cement applicators should always be utilized (i.e., no less than 1/2 the pipe diameter). On 6" and larger IPS pipe come-alongs or other mechanical helpers are recommended to assist in joint assembly.

Threaded Transitions to metal systems must be made with appropriate fittings designed for plastic-to-metal connections. Spears® offers a variety of transition fittings including metal threaded adapter and the superior Special Reinforced (SR) Female Plastic Thread fittings for the best transition joints.

The chemical compatibility of any thread sealant, pastes, or lubricants with CPVC must be verified. Spears® recommends the use of Spears® **Blue 75™** Thread Sealant that has been tested for compatibility. If TFE sealant tape is used, it must be selected and applied correctly, according to manufacturer's instructions.

Flanged Connection can be used when properly assembled; a full-faced 1/8" thick elastomer gasket must be used. Flange alignment and system support is critical to prevent adverse stress loads. Flange bolts must **NEVER** be used to draw a flanged system connection together. Flange bolts, nuts, and washers must be properly selected and incrementally tightened in sequence to torque according to flange manufacturer's specifications. Thermoplastic flanges are typically rated at 150 psi for water at 73°F and must be de-rated for systems operating at elevated temperatures (i.e., hot water lines).

Hot Water Heater & Boiler Connections

Connection of CPVC CTS systems to hot water heaters must be made in accordance with code requirements. Typically, 6" metal nipples are required for direct connection to tanks, but approved CPVC CTS piping can be used for connection to temperature/pressure relief valves.

Schedule 80 IPS CPVC Boiler Connections generally *should not* be made directly to the boiler. Most boilers do not have suitable temperature variation control. Connections must assure that the temperature-pressure does not exceed the capability of the CPVC material.

System Pressure Testing

Hydrostatic pressure testing should commence only after all set and cure times for solvent cemented joints have been satisfied. The system should be pressure tested in accordance with local code requirements following industry accepted practices for thermoplastic systems.

Under slab installations that contain joints must be pressure tested before pouring the slab. **NOTE:** IAPMO IS 2098, "Installation Standard for CPVC Solvent Cemented Hot and Cold Water Distribution Systems," requires a test at 150 psi for 2 hours.

In freezing temperatures the system should be adequately purged of water after testing to avoid damage from freezing.



CPVC CTS FITTINGS & VALVES

CPVC 41, SDR 11 PIPE DIMENSIONS (CTS) ASTM D 2846, D 2846M

Nominal Pipe Size In.	Mean Outside Diameter In.	O. D. Tolerance In.	Minimum Wall Thickness In.
1/2	0.625	± 0.003	0.068
3/4	0.875	± 0.003	0.080
1	1.125	± 0.003	0.102
1-1/4	1.375	± 0.003	0.125
1-1/2	1.625	± 0.004	0.148
2	2.125	± 0.004	0.193

CPVC 41, SDR 11 SOCKET DIMENSIONS (CTS) ASTM D 2846, D 2846M

Nominal Size In.	Diameter			Socket Length Minimum C
	Entrance A	Bottom B	Tolerance In.	
1/2	0.633	0.619	± 0.003	0.500
3/4	0.884	0.870	± 0.003	0.700
1	1.135	1.121	± 0.003	0.900
1-1/4	1.386	1.372	± 0.003	1.100
1-1/2	1.640	1.622	± 0.004	1.300
2	2.141	2.123	± 0.004	1.700

Injection Molded Dimension References:

- G** = (LAYING LENGTH) intersection of center lines to bottom of socket/thread; 90° elbows, tees, crosses; ± 1/32 inch.
- H** = Intersection of center lines to face of fitting; 90° elbows, tees, crosses; ± 1/32 inch.
- J** = Intersection of center lines to bottom of socket/thread; 45° elbows; ± 1/32 inch.
- L** = Overall length of fittings; ± 1/16 inch.
- M** = Outside diameter of socket/thread hub; ± 1/16 inch.
- N** = Socket bottom to socket bottom; couplings; ± 1/16 inch.
- W** = Height of cap; ± 1/16 inch.

COPPER TUBE SIZE (CTS) CPVC PIPE

Nominal Pipe Size In.	AVG. O.D.	AVG. I.D.	MIN. Wall	MAX. W.P. P.S.I. *	LBS./FT.	Lgths./Carton
1/2	0.625	0.469	0.068	400	.090	50
3/4	0.875	0.695	0.080	400	.149	25
1	1.125	0.901	0.102	400	.240	15
1-1/4	1.375	1.105	0.125	400	.353	10
1-1/2	1.625	1.309	0.148	400	.489	6
2	2.125	1.716	0.193	400	.829	4

Standard Length - 10 Feet • All pipe is packed in boxes sold in carton quantities only.
Pipe has UL 94 V-O rating • * For water, non shock, at 73.4°F with solvent welded joints.

CPVC CTS FITTINGS & VALVES



TEE

Socket x Socket x Socket

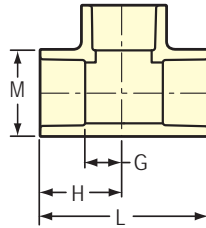

Part Number	Size	G	H	L	M	Approx. Wt. (Lbs.)
4101-005	1/2	13/32	15/16	1-27/32	27/32	.03
4101-007	3/4	17/32	1-1/4	2-1/2	1-3/32	.06
4101-010	1	21/32	1-9/16	3-5/32	1-3/8	.12
4101-012	1-1/4	25/32	1-7/8	3-25/32	1-11/16	.18
4101-015	1-1/2	29/32	2-7/32	4-15/32	1-15/16	.29
4101-020	2	1-5/32	2-7/8	5-25/32	2-9/16	.63

DROP EAR TEE

(Fitting With Bracket)

Socket x Socket x Socket

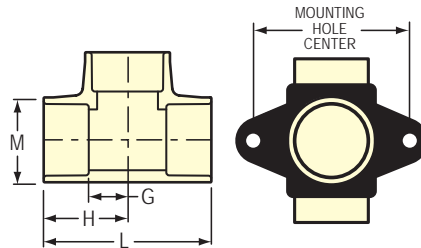

Part Number	Size	G	H	L	M	Mounting Hole Center	Approx. Wt. (Lbs.)
DE4101-005	1/2	13/32	15/16	1-7/8	27/32	1-3/4	.04

REDUCING TEE

Socket x Socket x Socket

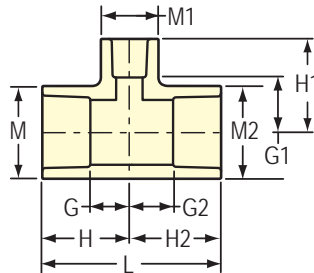

Part Number	Size	G	G1	G2	H	H1	H2	L	M	M1	M2	Approx. Wt. (Lbs.)
4101-074	1/2x1/2x3/4	7/16	13/32	31/32	31/32	1-1/8	31/32	1-15/16	27/32	1-3/32	27/32	.04



CPVC CTS FITTINGS & VALVES

REDUCING TEE (continued)

Socket x Socket x Socket

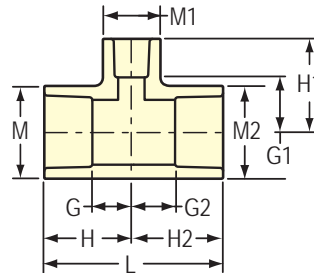

Part Number	Size	G	G1	G2	H	H1	H2	L	M	M1	M2	Approx. Wt. (Lbs.)
4101-094	3/4x1/2x1/2	7/16	17/32	7/16	1-5/32	1-1/32	31/32	2-1/8	1-3/32	27/32	27/32	.05
4101-095	3/4x1/2x3/4	1/2	17/32	19/32	1-7/32	1-1/4	1-1/8	2-11/32	1-3/32	1-3/32	27/32	.06
4101-101	3/4x3/4x1/2	13/32	17/32	13/32	1-1/8	1-1/32	1-1/8	2-1/4	1-3/32	7/8	1-3/32	.05
4101-102 ¹	3/4x3/4x1	1-1/8	11/16	1-13/16	1-27/32	1-19/32	1-13/16	3-21/32	1-11/32	1-11/32	1-11/32	.16
4101-120 ¹	1x1/2x1/2	11/16	1-5/16	1-1/4	1-19/32	1-27/32	1-25/32	3-3/8	1-11/32	1-11/32	1-11/32	.20
4101-121 ¹	1x1/2x3/4	11/16	1-1/8	1-1/4	1-19/32	1-27/32	1-25/32	3-3/8	1-11/32	1-11/32	1-11/32	.18
4101-122 ¹	1x1/2x1	11/16	11/16	1-1/4	1-19/32	1-19/32	1-25/32	3-3/8	1-11/32	1-11/32	1-11/32	.15
4101-124 ¹	1x3/4x1/2	11/16	1-5/16	1-1/16	1-19/32	1-27/32	1-25/32	3-3/8	1-11/32	1-11/32	1-11/32	.18
4101-125	1x3/4x3/4	17/32	11/16	17/32	1-15/32	1-13/32	1-1/4	2-23/32	1-11/32	1-3/32	1-3/32	.08
4101-126 ¹	1x3/4x1	11/16	15/16	1-1/16	1-19/32	1-27/32	1-25/32	3-3/8	1-11/32	1-11/32	1-11/32	.13
4101-130	1x1x1/2	13/32	11/16	13/32	1-11/32	1-7/32	1-11/32	2-21/32	1-3/8	7/8	1-3/8	.07
4101-131	1x1x3/4	9/16	11/16	9/16	1-15/32	1-13/32	1-15/32	2-15/16	1-3/8	1-3/32	1-3/8	.09
4101-138 ¹	1-1/4x1/2x1/2	13/16	1-11/16	1-21/32	1-29/32	2-7/32	2-3/16	4-3/32	1-21/32	1-21/32	1-21/32	.30
4101-139 ¹	1-1/4x1/2x3/4	13/16	1-1/2	1-21/32	1-29/32	2-7/32	2-3/16	4-3/32	1-21/32	1-21/32	1-21/32	.30
4101-142 ¹	1-1/4x1/2x1-1/4	13/16	27/32	1-21/32	1-29/32	1-15/16	2-3/16	4-3/32	1-21/32	1-21/32	1-21/32	.24
4101-146 ¹	1-1/4x3/4x1/2	13/16	1-11/16	1-15/32	1-29/32	2-7/32	2-3/16	4-3/32	1-21/32	1-21/32	1-21/32	.30
4101-147 ¹	1-1/4x3/4x3/4	13/16	1-1/2	1-15/32	1-29/32	2-7/32	2-3/16	4-3/32	1-21/32	1-21/32	1-21/32	.31
4101-148 ¹	1-1/4x3/4x1	13/16	1-5/16	1-15/32	1-29/32	2-7/32	2-3/16	4-3/32	1-21/32	1-21/32	1-21/32	.29
4101-149 ¹	1-1/4x3/4x1-1/4	25/32	25/32	1-7/16	1-29/32	1-29/32	2-3/16	4-3/32	1-21/32	1-21/32	1-21/32	.26
4101-156 ¹	1-1/4x1x1/2	13/16	1-21/32	1-1/4	1-29/32	2-3/16	2-5/32	4-1/16	1-21/32	1-21/32	1-21/32	.30
4101-157 ¹	1-1/4x1x3/4	13/16	1-1/2	1-9/32	1-29/32	2-7/32	2-3/16	4-3/32	1-21/32	1-21/32	1-21/32	.29
4101-158 ¹	1-1/4x1x1	13/16	1-5/16	1-9/32	1-29/32	2-7/32	2-3/16	4-3/32	1-21/32	1-21/32	1-21/32	.27
4101-159 ¹	1-1/4x1x1-1/4	13/16	27/32	1-9/32	1-29/32	1-15/16	2-3/16	4-3/32	1-21/32	1-21/32	1-21/32	.22
4101-166	1-1/4x1-1/4x1/2	11/32	27/32	13/32	1-17/32	1-11/32	1-17/32	3-9/16	1-21/32	7/8	1-21/32	.12
4101-167	1-1/4x1-1/4x3/4	17/32	13/16	17/32	1-21/32	1-17/32	1-21/32	3-5/16	1-21/32	1-1/8	1-21/32	.13
4101-168	1-1/4x1-1/4x1	11/16	13/16	11/16	1-25/32	1-3/4	1-25/32	3-19/32	1-21/32	1-3/8	1-21/32	.15
4101-169 ¹	1-1/4x1-1/4x1-1/2	1-7/16	15/16	2-1/32	2-17/32	2-1/4	2-17/32	5-1/16	1-31/32	1-31/32	1-31/32	.41
4101-173 ¹	1-1/2x1/2x1/2	15/16	2-1/32	2-1/32	2-1/4	2-9/16	2-9/16	4-13/16	1-31/32	1-31/32	1-31/32	.49
4101-174 ¹	1-1/2x1/2x3/4	15/16	1-27/32	2-1/32	2-1/4	2-9/16	2-9/16	4-13/16	1-31/32	1-31/32	1-31/32	.49
4101-175 ¹	1-1/2x1/2x1	11/16	1	1-13/16	2	1-29/32	2-11/32	4-11/32	1-31/32	1-3/8	1-31/32	.48
4101-176 ¹	1-1/2x1/2x1-1/4	15/16	1-15/32	2-1/32	2-1/4	2-9/16	2-9/16	4-13/16	1-31/32	1-31/32	1-31/32	.45
4101-177 ¹	1-1/2x1/2x1-1/2	15/16	15/16	2-1/32	2-1/4	2-1/4	2-9/16	4-13/16	1-31/32	1-31/32	1-31/32	.39
4101-182 ¹	1-1/2x3/4x1/2	15/16	2-1/32	1-27/32	2-1/4	2-9/16	2-9/16	4-13/16	1-31/32	1-31/32	1-31/32	.49

¹ Outlet sized with bushing

CPVC CTS FITTINGS & VALVES



REDUCING TEE

Socket x Socket x Socket

(continued)

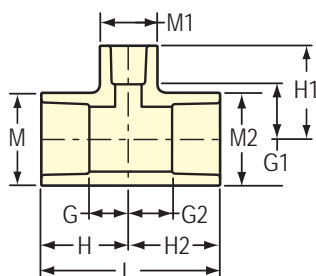

Part Number	Size	G	G1	G2	H	H1	H2	L	M	M1	M2	Approx. Wt. (Lbs.)
4101-184 ¹	1-1/2x3/4x3/4	15/16	1-27/32	1-27/32	2-1/4	2-9/16	2-9/16	4-13/16	1-31/32	1-31/32	1-31/32	.48
4101-185 ¹	1-1/2x3/4x1	1-1/32	1-5/8	1-27/32	2-1/4	2-9/16	2-9/16	4-23/32	1-31/32	1-31/32	1-31/32	.48
4101-186 ¹	1-1/2x3/4x1-1/4	3/4	1-7/16	1-5/16	2-9/16	2-9/16	2-1/4	4-13/16	1-31/32	1-31/32	1-31/32	.44
4101-188 ¹	1-1/2x3/4x1-1/2	15/16	15/16	1-27/32	2-1/4	2-1/4	2-9/16	4-13/16	1-31/32	1-31/32	1-31/32	.39
4101-193 ¹	1-1/2x1x1/2	15/16	2-1/32	1-21/32	2-1/4	2-9/16	2-9/16	4-13/16	1-31/32	1-31/32	1-31/32	.48
4101-194 ¹	1-1/2x1x3/4	15/16	1-27/32	1-21/32	2-1/4	2-9/16	2-9/16	4-13/16	1-31/32	1-31/32	1-31/32	.48
4101-195 ¹	1-1/2x1x1	15/16	1-21/32	1-21/32	2-1/4	2-9/16	2-9/16	4-27/32	1-31/32	1-31/32	1-31/32	.48
4101-196 ¹	1-1/2x1x1-1/4	15/16	1-15/32	1-11/16	2-1/4	2-9/16	2-19/32	4-27/32	1-31/32	1-31/32	1-31/32	.44
4101-197 ¹	1-1/2x1x1-1/2	15/16	15/16	1-21/32	2-1/4	2-1/4	2-9/16	4-13/16	1-31/32	1-31/32	1-31/32	.38
4101-199 ¹	1-1/2x1-1/4x1/2	1-3/8	2-1/32	2-1/32	2-1/2	2-9/16	2-1/4	4-23/32	1-31/32	1-31/32	1-31/32	.45
4101-201 ¹	1-1/2x1-1/4x3/4	15/16	1-27/32	1-15/32	2-1/4	2-9/16	2-9/16	4-13/16	1-31/32	1-31/32	1-31/32	.44
4101-202 ¹	1-1/2x1-1/4x1	15/16	1-21/32	1-15/32	2-1/4	2-9/16	2-9/16	4-13/16	1-31/32	1-31/32	1-31/32	.44
4101-203 ¹	1-1/2x1-1/4x1-1/4	15/16	1-15/32	1-15/32	2-1/4	2-9/16	2-9/16	4-13/16	1-31/32	1-31/32	1-31/32	.41
4101-204 ¹	1-1/2x1-1/4x1-1/2	15/16	15/16	1-15/32	2-1/4	2-1/4	2-9/16	4-13/16	1-31/32	1-31/32	1-31/32	.35
4101-209 ¹	1-1/2x1-1/2x1/2	11/16	1-1/2	2	2	2-3/16	2	4	1-31/32	1-3/8	1-31/32	.28
4101-210 ¹	1-1/2x1-1/2x3/4	11/16	1-7/16	2	2	2-5/32	2	4	1-31/32	1-3/8	1-31/32	.26
4101-211	1-1/2x1-1/2x1	11/16	31/32	11/16	2	1-29/32	1-31/32	3-31/32	1-15/16	1-3/8	1-15/16	.22
4101-212 ¹	1-1/2x1-1/2x1-1/4	15/16	1-7/16	2-7/32	2-1/4	2-17/32	2-7/32	4-15/32	1-31/32	1-31/32	1-31/32	.35
4101-213 ¹	1-1/2x1-1/2x2	1-29/32	1-3/16	1-29/32	3-7/32	2-7/8	3-19/32	6-13/16	2-9/16	2-9/16	2-9/16	1.01
4101-216 ¹	2x1/2x1/2	1-3/16	2-11/16	2-5/8	2-29/32	3-7/32	3-5/32	6-1/16	2-9/16	2-9/16	2-9/16	1.02
4101-217 ¹	2x1/2x3/4	1-3/16	2-1/2	2-5/8	2-29/32	3-7/32	3-5/32	6-1/16	2-9/16	2-9/16	2-9/16	1.03
4101-218 ¹	2x1/2x1	1-3/16	2-5/16	2-5/8	2-29/32	3-7/32	3-5/32	6-1/16	2-9/16	2-9/16	2-9/16	1.03
4101-219 ¹	2x1/2x1-1/4	1-3/16	2-1/8	2-5/8	2-29/32	3-7/32	3-5/32	6-1/16	2-9/16	2-9/16	2-9/16	1.02
4101-220 ¹	2x1/2x1-1/2	1-3/16	1-29/32	2-5/8	2-29/32	3-7/32	3-5/32	6-1/16	2-9/16	2-9/16	2-9/16	1.00
4101-221 ¹	2x1/2x2	1-3/16	1-5/32	2-5/8	2-29/32	2-7/8	3-5/32	6-1/16	2-9/16	2-9/16	2-9/16	.82
4101-222 ¹	2x3/4x1/2	1-3/16	2-11/16	2-11/16	2-29/32	3-7/32	3-5/32	6-1/16	2-9/16	2-9/16	2-9/16	1.03
4101-223 ¹	2x3/4x3/4	1-3/16	2-1/2	2-7/16	2-29/32	3-7/32	3-5/32	6-1/16	2-9/16	2-9/16	2-9/16	1.04
4101-224 ¹	2x3/4x1	1-3/16	2-5/16	2-7/16	2-29/32	3-7/32	3-5/32	6-1/16	2-9/16	2-9/16	2-9/16	1.04
4101-225 ¹	2x3/4x1-1/4	1-5/32	2-1/16	2-7/16	2-7/8	3-5/32	3-5/32	6-1/16	2-9/16	2-9/16	2-9/16	1.03
4101-226 ¹	2x3/4x1-1/2	1-3/16	1-29/32	2-7/16	2-29/32	3-7/32	3-5/32	6-1/16	2-9/16	2-9/16	2-9/16	1.01
4101-227 ¹	2x3/4x2	1-3/16	1-5/32	2-7/16	2-29/32	2-7/8	3-5/32	6-1/16	2-9/16	2-9/16	2-9/16	.83
4101-228 ¹	2x1x1/2	1-3/16	2-11/16	2-1/4	2-29/32	3-7/32	3-5/32	6-1/16	2-9/16	2-9/16	2-9/16	1.03
4101-229	2x1x3/4	1-23/32	2-1/2	2-1/4	2-7/8	3-3/16	3-7/32	6-3/32	2-9/16	2-9/16	2-9/16	1.04
4101-230 ¹	2x1x1	1-3/16	2-5/16	2-1/4	2-29/32	3-7/32	3-5/32	6-1/16	2-9/16	2-9/16	2-9/16	1.05

¹ Outlet sized with bushing



CPVC CTS FITTINGS & VALVES

REDUCING TEE (continued)

Socket x Socket x Socket

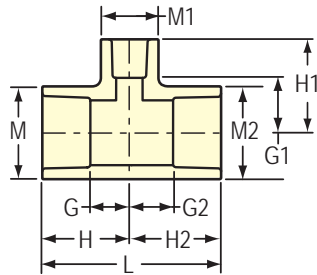

Part Number	Size	G	G1	G2	H	H1	H2	L	M	M1	M2	Approx. Wt. (Lbs.)
4101-231 ¹	2x1x1-1/4	1-3/16	2-1/8	2-1/4	2-29/32	3-7/32	3-5/32	6-1/16	2-9/16	2-9/16	2-9/16	1.04
4101-232 ¹	2x1x1-1/2	1-3/16	1-29/32	2-1/4	2-29/32	3-7/32	3-5/32	6-1/16	2-9/16	2-9/16	2-9/16	1.02
4101-233 ¹	2x1x2	1-3/16	1-5/32	2-1/4	2-29/32	2-7/8	3-5/32	6-1/16	2-9/16	2-9/16	2-9/16	.83
4101-234 ¹	2x1-1/4x1/2	1-3/16	2-11/16	2-1/16	2-29/32	3-7/32	3-5/32	6-1/16	2-9/16	2-9/16	2-9/16	1.02
4101-235 ¹	2x1-1/4x3/4	1-3/16	2-1/2	2-1/16	2-29/32	3-7/32	3-5/32	6-1/16	2-9/16	2-9/16	2-9/16	1.03
4101-236 ¹	2x1-1/4x1	1-3/16	2-5/16	2-1/16	2-29/32	3-7/32	3-5/32	6-1/16	2-9/16	2-9/16	2-9/16	1.04
4101-237 ¹	2x1-1/2x1/2	1-3/16	2-11/16	1-27/32	2-29/32	3-7/32	3-5/32	6-1/16	2-9/16	2-9/16	2-9/16	1.00
4101-238 ¹	2x1-1/2x3/4	1-3/16	2-1/2	1-27/32	2-29/32	3-7/32	3-5/32	6-1/16	2-9/16	2-9/16	2-9/16	1.01
4101-239 ¹	2x1-1/2x1	1-3/16	2-5/16	1-27/32	2-29/32	3-7/32	3-5/32	6-1/16	2-9/16	2-9/16	2-9/16	1.02
4101-240 ¹	2x1-1/2x1-1/4	1-3/16	2-1/8	1-27/32	2-29/32	3-7/32	3-5/32	6-1/16	2-9/16	2-9/16	2-9/16	1.00
4101-241 ¹	2x1-1/2x1-1/2	1-5/32	1-7/8	1-7/8	2-7/8	3-3/16	3-3/16	6-1/16	2-9/16	2-9/16	2-9/16	1.01
4101-242 ¹	2x1-1/4x1-1/4	1-3/16	2-1/8	2-1/16	2-29/32	3-7/32	3-5/32	6-1/16	2-9/16	2-9/16	2-9/16	1.02
4101-243 ¹	2x1-1/4x1-1/2	1-3/16	1-29/32	2-1/16	2-29/32	3-7/32	3-5/32	6-1/16	2-9/16	2-9/16	2-9/16	1.00
4101-244 ¹	2x1-1/4x2	1-5/32	1-1/2	2-3/32	2-7/8	3-7/32	3-3/16	6-1/16	2-9/16	2-9/16	2-9/16	.82
4101-247 ¹	2x2x1/2	21/32	1-7/8	21/32	2-3/8	2-13/32	2-3/8	4-25/32	2-9/16	1-3/8	2-9/16	.48
4101-248 ¹	2x2x3/4	11/16	1-5/8	11/16	2-13/32	2-11/32	2-13/32	4-25/32	2-17/32	1-13/32	2-17/32	.46
4101-249	2x2x1	11/16	1-9/32	11/16	2-13/32	2-3/16	2-13/32	4-25/32	2-17/32	1-3/8	2-17/32	.43
4101-250 ¹	2x2x1-1/4	1-5/32	2-3/8	1-5/32	2-7/8	3-7/32	2-7/8	5-25/32	2-9/16	2-9/16	2-9/16	.90
4101-251	2x2x1-1/2	31/32	1-1/4	31/32	2-11/16	2-9/16	2-11/16	5-3/8	2-17/32	1-31/32	2-17/32	.52
4101-257 ¹	2x1-1/2x2	1-3/16	1-5/32	1-27/32	2-29/32	2-7/8	3-5/32	6-1/16	2-9/16	2-9/16	2-9/16	.80

¹ Outlet sized with bushing

CPVC CTS FITTINGS & VALVES



90° ELBOW

Socket x Socket

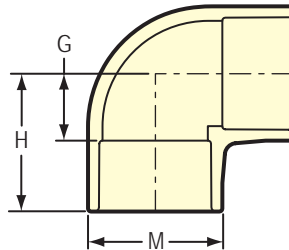

Part Number	Size	G	H	M	Approx. Wt. (Lbs.)
4106-005	1/2	13/32	15/16	27/32	.02
4106-007	3/4	17/32	1-1/4	1-1/8	.05
4106-010	1	21/32	1-9/16	1-3/8	.08
4106-012	1-1/4	3/4	1-7/8	1-11/16	.13
4106-015	1-1/2	29/32	2-7/32	2	.22
4106-020	2	1-5/32	2-7/8	2-19/32	.49

REDUCING 90° ELBOW

Socket x Socket

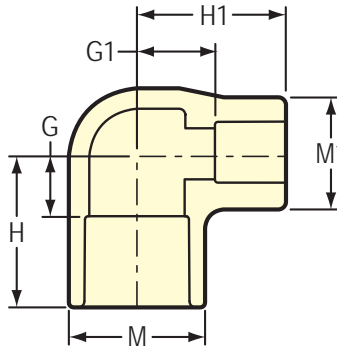

Part Number	Size	G	G1	H	H1	M	M1	Approx. Wt. (Lbs.)
4106-101	3/4x1/2	3/8	1/2	1-3/32	1-1/32	1-3/32	27/32	.04
4106-131 ¹	1x3/4	21/32	1	1-9/16	1-3/8	1-3/8	1-3/8	.10
4106-167 ¹	1-1/4x3/4	13/16	1-1/2	1-29/32	2-7/32	1-21/32	1-21/32	.20
4106-168 ¹	1-1/4x1	13/16	1-5/16	1-29/32	2-7/32	1-21/32	1-21/32	.18
4106-209 ¹	1-1/2x1/2	15/16	2-1/32	2-1/4	2-17/32	1-31/32	1-31/32	.32
4106-210 ¹	1-1/2x3/4	15/16	1-27/32	2-1/4	2-9/16	1-31/32	1-31/32	.32
4106-211 ¹	1-1/2x1	15/16	1-21/32	2-1/4	2-19/32	1-31/32	1-31/32	.31
4106-212 ¹	1-1/2x1-1/4	15/16	1-13/32	2-1/4	2-17/32	1-31/32	1-31/32	.28
4106-247 ¹	2x1/2	1-3/16	2-11/16	2-29/32	3-3/16	2-9/16	2-9/16	.67
4106-248 ¹	2x3/4	1-3/16	2-7/16	2-29/32	3-5/32	2-9/16	2-9/16	.68
4106-249 ¹	2x1	1-3/16	2-9/32	2-29/32	3-3/16	2-9/16	2-9/16	.68
4106-250 ¹	2x1-1/4	1-3/16	2-1/16	2-29/32	3-5/32	2-9/16	2-9/16	.67
4106-251 ¹	2x1-1/2	1-3/16	1-29/32	2-29/32	3-7/32	2-9/16	2-9/16	.65

¹ Outlet sized with bushing



CPVC CTS FITTINGS & VALVES

SPECIAL REINFORCED 90° ELBOW – LEAD FREE
 Socket x SR Fipt

Part Number	Size	G	G1	H	H1	M	M1	Approx. Wt. (Lbs.)
4107-005SR	1/2	13/32	13/32	15/16	1-5/32	27/32	1-7/32	.06

ZINC DROP EAR SPECIAL REINFORCED 90° ELBOW – LEAD FREE
 (One Piece Unit)
 Socket x SR Fipt – Zinc Collar

Part Number	Size	G	G1	H	H1	M	M1	Mounting Hole Center	Approx. Wt. (Lbs.)
DEZ4107-005SR	1/2	1/4	3/8	25/32	1-5/32	27/32	1-7/32	2-1/16	.15

DROP EAR 90° ELBOW
 (Fitting With Bracket)
 Socket x Socket

Part Number	Size	G	H	M	Mounting Hole Center	Approx. Wt. (Lbs.)
DE4106-005	1/2	1/4	25/32	27/32	1-3/4	.03

CPVC CTS FITTINGS & VALVES



DROP EAR SPECIAL REINFORCED 90° ELBOW – LEAD FREE

(Fitting With Bracket)

Socket x SR Fipt – Stainless Steel Collar

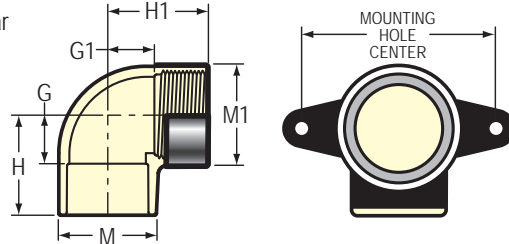

Part Number	Size	G	G1	H	H1	M	M1	Mounting Hole Center	Approx. Wt. (Lbs.)
DE4107-005SR	1/2	13/32	15/32	15/16	1-5/32	27/32	1-7/32	2-1/32	.07

90° STREET ELBOW

Spigot x Socket

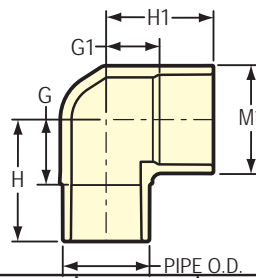

Part Number	Size	G	G1	H	H1	M1	Pipe O.D.	Approx. Wt. (Lbs.)
4109-005	1/2	17/32	3/8	1-1/16	7/8	7/8	5/8	.02
4109-007	3/4	19/32	17/32	1-5/16	1-1/4	1-1/32	7/8	.05
4109-010	1	25/32	21/32	1-13/16	1-9/16	1-11/32	1-1/8	.09

45° ELBOW

Socket x Socket

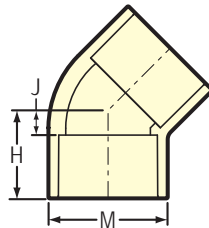

Part Number	Size	H	J	M	Approx. Wt. (Lbs.)
4117-005	1/2	23/32	7/32	27/32	.02
4117-007	3/4	31/32	7/32	1-1/8	.04
4117-010	1	1-7/32	9/32	1-3/8	.06
4117-012	1-1/4	1-15/32	11/32	1-11/16	.11
4117-015	1-1/2	1-3/4	7/16	1-31/32	.18
4117-020	2	2-1/4	17/32	2-9/16	.37



CPVC CTS FITTINGS & VALVES

45° STREET ELBOW

Spigot x Socket

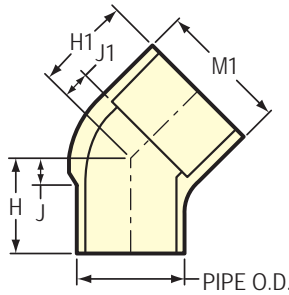

Part Number	Size	H	H1	J	J1	M1	Pipe O.D.	Approx. Wt. (Lbs.)
4127-005	1/2	3/4	23/32	7/32	7/32	27/32	5/8	.02
4127-007	3/4	1	1	9/32	9/32	1-3/32	7/8	.04
4127-010	1	1-5/16	1-11/32	3/8	7/16	1-3/8	1-1/8	.06

COUPLING

Socket x Socket

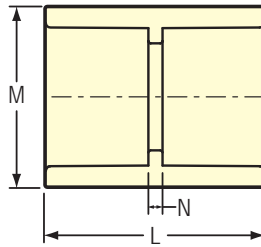

Part Number	Size	L	M	N	Approx. Wt. (Lbs.)
4129-005	1/2	1-5/32	27/32	1/8	.02
4129-007	3/4	1-9/16	1-1/16	1/8	.03
4129-010	1	1-15/16	1-3/8	1/8	.04
4129-012	1-1/4	2-3/8	1-21/32	3/32	.08
4129-015	1-1/2	2-3/4	1-31/32	1/8	.13
4129-020	2	3-9/16	2-9/16	1/8	.29

CPVC CTS FITTINGS & VALVES



REDUCER COUPLING

Socket x Socket

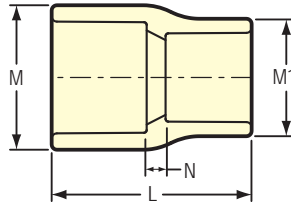

Part Number	Size	L	M	M1	N	Approx. Wt. (Lbs.)
4129-101	3/4x1/2	1-11/32	1-3/32	27/32	1/8	.02
4129-130 ¹	1x1/2	2-7/32	1-11/32	1-11/32	25/32	.09
4129-131	1x3/4	1-3/4	1-11/32	1-3/32	1/8	.04
4129-166 ¹	1-1/4x1/2	2-5/8	1-21/32	1-21/32	1	.14
4129-167 ¹	1-1/4x3/4	2-5/8	1-21/32	1-21/32	13/16	.15
4129-168 ¹	1-1/4x1	2-5/8	1-21/32	1-21/32	5/8	.13
4129-209 ¹	1-1/2x1/2	3-1/16	1-31/32	1-31/32	1-7/32	.24
4129-210 ¹	1-1/2x3/4	3-1/16	1-31/32	1-31/32	1-1/32	.23
4129-211 ¹	1-1/2x1	3-1/16	1-31/32	1-31/32	27/32	.23
4129-212 ¹	1-1/2x1-1/4	3-1/16	1-31/32	1-31/32	21/32	.19
4129-247 ¹	2x1/2	3-27/32	2-9/16	2-9/16	1-19/32	.49
4129-248 ¹	2x3/4	3-27/32	2-9/16	2-9/16	1-13/32	.50
4129-249 ¹	2x1	3-27/32	2-9/16	2-9/16	1-7/32	.50
4129-250 ¹	2x1-1/4	3-27/32	2-9/16	2-9/16	1-1/32	.49
4129-251 ¹	2x1-1/2	3-27/32	2-9/16	2-9/16	13/16	.47

¹ Outlet sized with bushing

FEMALE ADAPTER with GASKET

Socket x NPSC

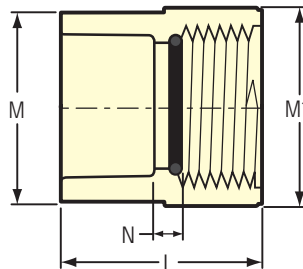

Part Number	Size	L	M	M1	N	Approx. Wt. (Lbs.)
4135-005OR	1/2	1-11/32	27/32	1-3/16	7/32	.04
4135-007OR	3/4	1-9/16	1-3/32	1-3/8	7/32	.05
4135-010OR	1	1-29/32	1-11/32	1-11/16	3/8	.09



CPVC CTS FITTINGS & VALVES

GASKET SEALED BRASS FEMALE ADAPTER – LEAD FREE

Socket x Gasket FIPT – Use NO Thread Sealant

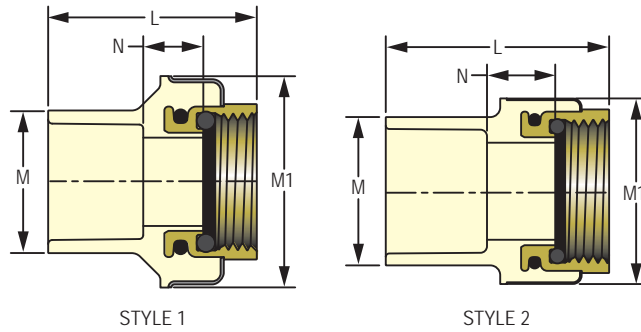

Part Number	Size	L	M	M1	N	Style	Approx. Wt. (Lbs.)
4135-005BRG	1/2	1-1/2	27/32	1-7/16	9/16	1	.12
4135-007BRG	3/4	1-9/16	1-3/32	1-5/8	15/32	1	.13
4135-010BRG	1	2-1/32	1-11/32	1-23/32	5/8	2	.21
4135-012BRG	1-1/4	2-7/32	1-21/32	2-1/16	19/32	2	.30
4135-015BRG	1-1/2	2-7/16	1-15/16	2-7/16	5/8	2	.41
4135-020BRG	2	2-27/32	2-17/32	3	19/32	2	.54

GASKET SEALED BRASS FEMALE ADAPTER – LEAD FREE

Socket x Gasket FIPT – Use NO Thread Sealant

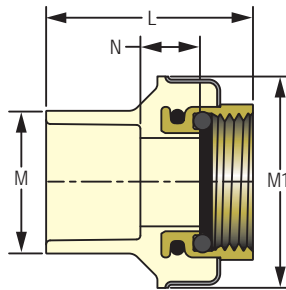

Part Number	Size	L	M	M1	N	Approx. Wt. (Lbs.)
4135-101BRG	3/4 x 1/2	1-9/16	1-3/32	1-7/16	7/16	.12
4135-130BRG	1 x 1/2	1-3/4	1-11/32	1-7/16	13/32	.13

CPVC CTS FITTINGS & VALVES



SPECIAL REINFORCED FEMALE ADAPTER - LEAD FREE

Socket x SR Fipt

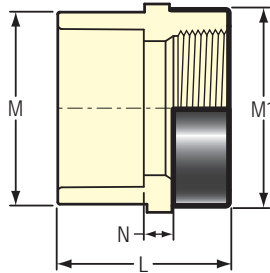

Part Number	Size	L	M	M1	N	Approx. Wt. (Lbs.)
4135-005SR	1/2	1-3/8	27/32	1-7/32	3/32	.05
4135-007SR	3/4	1-19/32	1-3/32	1-3/8	1/8	.06
4135-010SR	1	1-15/16	1-3/8	1-23/32	1/8	.10

SPECIAL REINFORCED REDUCING FEMALE ADAPTER - LEAD FREE

Socket x SR Fipt

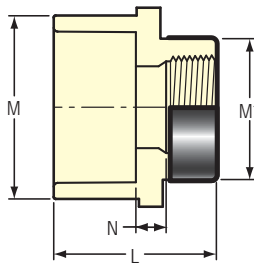

Part Number	Size	L	M	M1	N	Approx. Wt. (Lbs.)
4135-131SR	1x3/4	1-27/32	1-13/32	1-3/8	3/16	.08

MALE ADAPTER

Mipt x Socket

For Cold Water Service Only

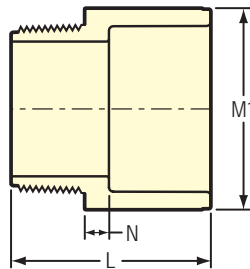

Part Number	Size	L	M1	N	Approx. Wt. (Lbs.)
4136-005	1/2	1-9/32	27/32	3/16	.02
4136-007	3/4	1-17/32	1-3/32	1/8	.04
4136-010	1	1-7/8	1-11/32	7/32	.05
4136-012	1-1/4	2-9/32	1-21/32	5/16	.09
4136-015	1-1/2	2-15/32	1-31/32	5/16	.13
4136-020	2	2-31/32	2-17/32	3/8	.25



CPVC CTS FITTINGS & VALVES

REDUCING MALE ADAPTER

Mipt x Socket

For Cold Water Service Only

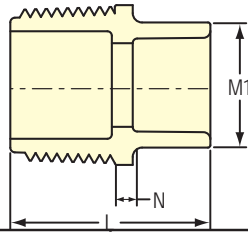

Part Number	Size	L	M1	N	Approx. Wt. (Lbs.)
4136-074	1/2x3/4	1-17/32	1-3/32	5/32	.03
4136-101	3/4x1/2	1-11/32	27/32	1/8	.02

REINFORCED MALE ADAPTER - LEAD FREE

(Internal Stainless Steel Reinforced)

R Mipt x Socket

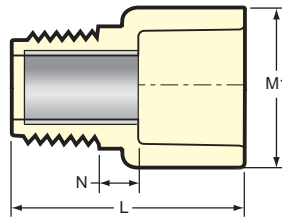

Part Number	Size	L	M1	N	Approx. Wt. (Lbs.)
4136-005R	1/2	1-23/32	27/32	17/32	.04
4136-007R	3/4	1-15/16	1-3/32	9/16	.06
4136-010R	1	2-3/8	1-11/32	11/16	.11

TRANSITION MALE ADAPTER - LEAD FREE

Brass Mipt x Socket

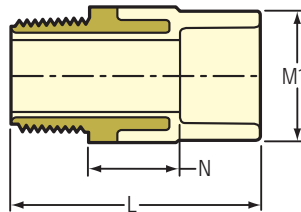

Part Number	Size	L	M1	N	Approx. Wt. (Lbs.)
4136-005BR	1/2	2	27/32	25/32	.14
4136-007BR	3/4	2-1/4	1-3/16	27/32	.21
4136-010BR	1	2-11/16	1-3/8	29/32	.38
4136-012BR	1-1/4	2-31/32	1-21/32	31/32	.61
4136-015BR	1-1/2	3-3/16	1-15/16	1-1/32	.74
4136-020BR	2	3-21/32	2-17/32	31/32	.97

CPVC CTS FITTINGS & VALVES



MALE ADAPTER

Mipt x Spigot

For Cold Water Service Only

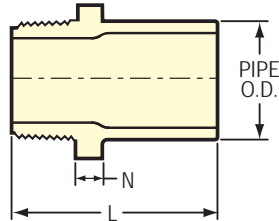

Part Number	Size	L	N	Pipe O.D.	Approx. Wt. (Lbs.)
4161-005	1/2	1-5/16	3/16	5/8	.02

REDUCER BUSHING

Spigot x Socket

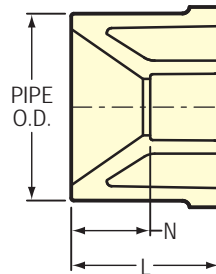

Part Number	Size	L	N	Pipe O.D.	Approx. Wt. (Lbs.)
4137-101	3/4x1/2	27/32	1/8	7/8	.02
4137-130	1x1/2	1-1/8	5/8	1-1/8	.05
4137-131	1x3/4	1-1/16	7/16	1-1/8	.02
4137-166	1-1/4x1/2	1-13/32	7/8	1-3/8	.06
4137-167	1-1/4x3/4	1-3/8	21/32	1-3/8	.06
4137-168	1-1/4x1	1-5/16	3/8	1-3/8	.04
4137-209	1-1/2x1/2	1-21/32	1-1/8	1-5/8	.10
4137-210	1-1/2x3/4	1-5/8	29/32	1-5/8	.10
4137-211	1-1/2x1	1-19/32	21/32	1-5/8	.09
4137-212	1-1/2x1-1/4	1-19/32	7/16	1-5/8	.06
4137-247	2x1/2	2	1-15/32	2-1/8	.20
4137-248	2x3/4	2	1-9/32	2-1/8	.21
4137-249	2x1	2	1-3/32	2-1/8	.21
4137-250	2x1-1/4	1-31/32	7/8	2-1/8	.21
4137-251	2x1-1/2	2-1/32	23/32	2-1/8	.19



CPVC CTS FITTINGS & VALVES

TRANSITION BUSHING

IPS Spigot x CTS Socket

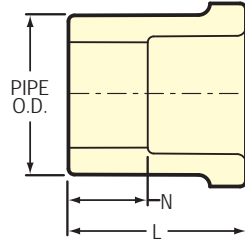

Part Number	Size	L	N	Pipe O.D.	Approx. Wt. (Lbs.)
4140-005	1/2	15/16	13/32	27/32	.02
4140-007	3/4	1-1/8	1/2	1-1/16	.02
4140-010	1	1-3/8	15/32	1-5/16	.04
4140-012	1-1/4	1-17/32	3/8	1-21/32	.07
4140-015	1-1/2	1-21/32	5/16	1-29/32	.08
4140-020	2	1-27/32	1/8	2-3/8	.10

TRANSITION COUPLING

IPS Socket x CTS Socket

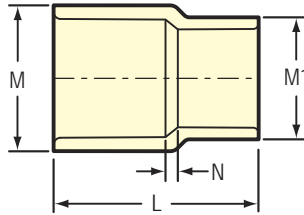

Part Number	Size	L	M	M1	N	Approx. Wt. (Lbs.)
4141-007	3/4	1-27/32	1-5/16	1-3/32	1/8	.04
4141-010	1	2-5/32	1-19/32	1-3/8	1/8	.07

CPVC CTS FITTINGS & VALVES



CAP

Socket

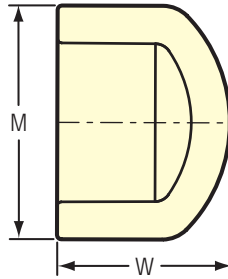

Part Number	Size	M	W	Approx. Wt. (Lbs.)
4147-005	1/2	27/32	25/32	.01
4147-007	3/4	1-1/16	1-3/32	.02
4147-010	1	1-3/8	1-9/32	.04
4147-012	1-1/4	1-21/32	1-19/32	.06
4147-015	1-1/2	1-31/32	1-29/32	.10
4147-020	2	2-9/16	2-13/32	.21

CTS BALL VALVES

w/EPDM O-ring Seals

Socket x Socket

100 psi Maximum
Internal Pressure @ 180°F

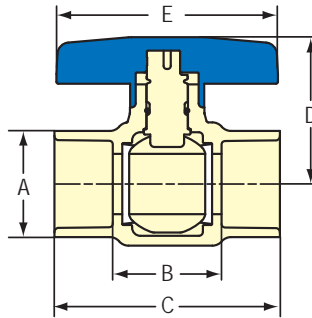

Part Number	Size	A	B	C	D	E	Approx. Wt. (Lbs.)	Cv Values
1922-005	1/2	1-7/32	1-1/16	2-3/32	1-11/32	2	.09	37
1922-007	3/4	1-9/16	1-11/32	2-25/32	1-3/4	2-23/32	.16	84
1922-010	1	1-7/8	1-9/16	3-3/8	2-3/8	3-1/2	.27	151
1922-012	1-1/4	2-13/32	1-15/16	4-3/16	2-25/32	3-3/4	.47	229
1922-015	1-1/2	2-27/32	2-3/8	5-1/32	3-5/32	4-9/32	1.05	330
1922-020	2	3-17/32	2-3/4	6-3/16	3-27/32	5	1.38	598



CPVC CTS FITTINGS & VALVES

CTS UNION

w/EPDM O-ring Seals
Socket x Socket

Pressure Rating
100 psi @ 180°F

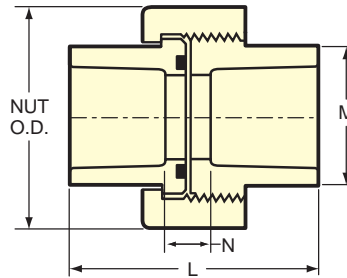

Part Number	Size	L	M	N	NUT O.D.	Approx. Wt. (Lbs.)
4197-005	1/2	2-3/16	1-1/32	1-5/32	1-25/32	.13
4197-007	3/4	1-3/4	1-3/32	5/16	1-23/32	.08
4197-010	1	2-13/32	1-17/32	9/16	2-1/2	.27

GASKET SEALED BRASS ADAPTER UNION – LEAD FREE

w/EPDM O-ring Seals
Socket x Gasket FIPT With Elastomer Seal

Pressure Rating
100 psi @ 180°F

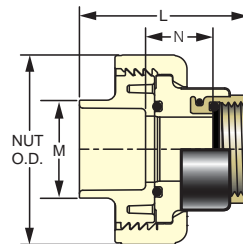

Part Number	Size	L	M	N	Nut O.D.	Approx. Wt. (Lbs.)
4199-005BRG	1/2	1-5/8	2-1/8	3/4	2-1/8	---
4199-007BRG	3/4	1-7/8	2-5/16	3/4	2-5/16	---
4199-010BRG	1	2-3/8	2-5/8	15/16	2-5/8	---

1/4 -TURN ANGLE SUPPLY STOP

w/EPDM O-ring Seals
Socket x NPT

Pressure Rating
100 psi @ 180°F

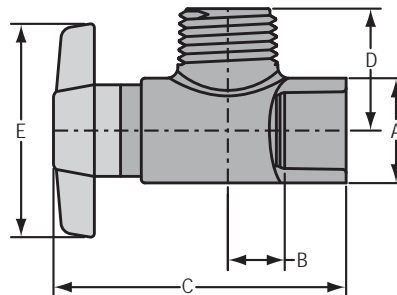

Part Number	Size	A	B	C	D	E	Approx. Wt. (Lbs.)
7722-005	1/2	27/32	7/16	2-13/32	1	1-3/4	.06

CPVC CTS FITTINGS & VALVES



1/4 -TURN ANGLE SUPPLY STOP

w/EPDM O-ring Seals
SR Fipt x NPT

Pressure Rating
100 psi @ 180°F

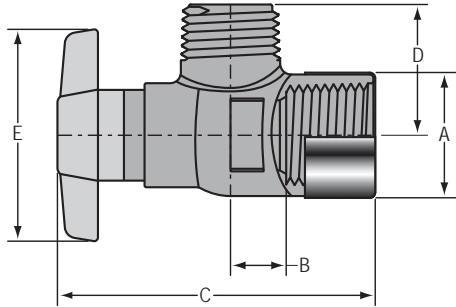

Part Number	Size	A	B	C	D	E	Approx. Wt. (Lbs.)
7721-005SR	1/2	1	15/32	2-21/32	1	1-3/4	.10

1/4 -TURN ANGLE SUPPLY STOP

w/EPDM O-ring Seals
Socket x 3/8" O.D. Comp. For Flex Tube Only

Pressure Rating
100 psi @ 180°F

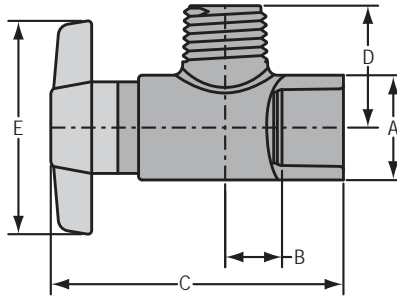

Part Number	Size	A	B	C	D	E	Approx. Wt. (Lbs.)
7722-073	1/2 x 3/8	7/8	7/16	2-3/8	7/8	1-3/4	.05

1/4 -TURN ANGLE SUPPLY STOP

w/EPDM O-ring Seals
SR Fipt x 3/8" O.D. Comp. For Flex Tube Only

Pressure Rating
100 psi @ 180°F

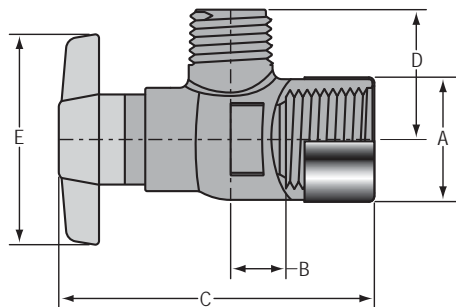

Part Number	Size	A	B	C	D	E	Approx. Wt. (Lbs.)
7721-073SR	1/2 x 3/8	1-1/32	15/32	2-5/8	31/32	1-3/4	.09